

# STELLAR® FLEX36 HOOKLIFT HOIST

## ■ SPECIFICATION INFORMATION

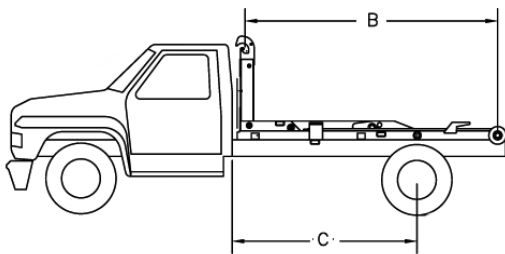
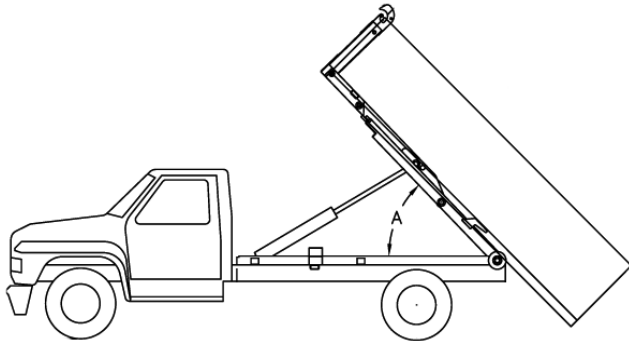

- Will accommodate bodies from 8-feet up to 15-feet long and still retain the maximum rated dump angle on a 41-inch high frame truck. Longer bodies may be accommodated with reduced dumping capabilities.
- Transmission-mounted PTO and hydraulic pump required to power the hooklift.
- Standard in-cab manual controls which allow for precise metering of the manual hydraulic valve.
- Ten (10) gallon capacity frame-mounted oil reservoir.
- Maximum hydraulic flow is 16-gallons per minute.
- Patented dump/load interface on double pivot models.
- Counter balance valves to prevent cylinder movement in case of pressure loss.
- Mechanical rear body tie-down latches.
- Resettable dump/tilt tabs.
- Hydraulic rotary valve to prevent front tilt movement when the dump frame is raised.
- Permanently lubricated and greaseable bushings used throughout.
- Grease zerks at all pin points to allow purging of contaminants.
- Carbon steel and zinc plated or type 17-4 stainless steel pins used throughout.
- All weldments painted with two-part polyurethane enamel.

Item Description	60-8	84-10	108-12	120-14
<b>A</b> Dump Angle	54°	53°	54°	50°
<b>B</b> Effective Length	91" (2,311 mm)	115" (2,921 mm)	142" (3,607 mm)	151" (3,835 mm)
<b>C</b> Cab to Axle	60" (1,524 mm)	84"-96" (2,134-2,438 mm)	108"-120" (2,743-3,048 mm)	120"-130" (3,048-3,302 mm)
Lifting / Dumping Cap.	Up to 9,000 lb. (4,082 kg)	Up to 16,000 lb. (7,257 kg)	Up to 16,000 lb. (7,257 kg)	Up to 16,000 lb. (7,257 kg)
Shipping Weight	1,275 lb. (578 kg)	1,360 lb. (617 kg)	1,615 lb. (733 kg)	1,650 lb. (748 kg)
Rec. Body Lengths	8'-9' (2,438-2,743 mm)	10'-12' (3,048-3,658 mm)	12'-14' (3,658-4,267 mm)	13'-15' (3,962-4,572 mm)
Hook Height	35.63" (905 mm)	35.63" (905 mm)	35.63" (905 mm)	35.63" (905 mm)
Min. Truck GVWR	10,500-15,000 lb. (4,763-6,804 kg)	10,500-26,000 lb. (4,763-11,793 kg)	10,500-26,000 lb. (4,763-11,793 kg)	10,500-26,000 lb. (4,763-11,793 kg)

■ Stellar® Hooklift Reference Chart\*

Model	Hook Height	Lift Capacity (lbs)	Effective Length (in)	Body Lengths (ft)	Cab-To-Axle/Trunnion
Flex36 60-8	35.63 (905 mm)	Up to 9,000 (4,082 kg)	92 (2,337 mm)	8-9 (2,438-2,743 mm)	60 C.A. (1,524 mm)
Flex36 84-10	35.63 (905 mm)	16,000 (7,257 kg)	115 (2,921 mm)	10-12 (3,048-3,658 mm)	84-96 C.A. (2,134-2,438 mm)
Flex36 108-12	35.63 (905 mm)	16,000 (7,257 kg)	142 (3,607 mm)	12-14 (3,658-4,267 mm)	108-120 C.A. (2,743-3,048 mm)
Flex36 120-14	35.63 (905 mm)	16,000 (7,257 kg)	151 (3,835 mm)	13-15 (3,962-4,572 mm)	120-130 C.A. (3,048-3,302 mm)
108-12-20/36	35.63 (905 mm)	20,000 (9,072 kg)	126 (3,200 mm)	12-13.5 (3,658-4,115 mm)	102-108 C.A. (2,591-2,743 mm)
108-11-20	54 (1,372 mm)	20,000 (9,072 kg)	127 (3,226 mm)	11-13.5 (3,353-4,115 mm)	102-108 C.A. (2,591-2,743 mm)
120-16-20	54 (1,372 mm)	20,000 (9,072 kg)	146 (3,708 mm)	12.5-15 (3,810-4,572 mm)	114-130 C.A. (2,896-3,302 mm)
138-18-20	54 (1,372 mm)	20,000 (9,072 kg)	171 (4,343 mm)	14.5-17 (4,420-5,182 mm)	130-144 C.A. (3,302-3,658 mm)
168-20-20	61.75 (1,568 mm)	20,000 (9,072 kg)	195 (4,953 mm)	16.5-19 (5,029-5,791 mm)	168-180 C.A. (4,267-4,572 mm)
190-24-20	61.75 (1,568 mm)	20,000 (9,072 kg)	222 (5,639 mm)	18.5-21.5 (5,639-6,553 mm)	190-200 C.A. (4,826-5,080 mm)
96-10-24	54 (1,372 mm)	24,000 (10,886 kg)	115 (2,921 mm)	10-12.5 (3,048-3,810 mm)	84-102 C.A. (2,134-2,591 mm)
108-14-32	61.75 (1,568 mm)	32,000 (14,515 kg)	144 (3,658 mm)	12-15 (3,658-4,572 mm)	102-108 C.T. (2,590-2,743 mm)
138-18-32	61.75 (1,568 mm)	32,000 (14,515 kg)	176 (4,470 mm)	15-17.5 (4,572-5,334 mm)	130-144 C.T. (3,302-3,658 mm)
174-20-32	61.75 (1,568 mm)	32,000 (14,515 kg)	206 (5,232 mm)	17.5-20 (5,334-6,096 mm)	160-174 C.T. (4,064-4,420 mm)
190-24-32	61.75 (1,568 mm)	32,000 (14,515 kg)	223 (5,664 mm)	19-21.5 (5,791-6,553 mm)	174-190 C.T. (4,420-4,826 mm)
138-18-34	54 (1,372 mm)	34,000 (15,422 kg)	176 (4,470 mm)	15-17.5 (4,572-5,334 mm)	130-144 C.T. (3,302-3,658 mm)
108-14-40	61.75 (1,568 mm)	40,000 (18,144 kg)	144 (3,658 mm)	12-15 (3,658-4,572 mm)	102-108 C.T. (2,591-2,743 mm)
138-18-40	61.75 (1,568 mm)	40,000 (18,144 kg)	176 (4,470 mm)	15-17.5 (4,572-5,334 mm)	130-144 C.T. (3,302-3,658 mm)
174-20-40	61.75 (1,568 mm)	40,000 (18,144 kg)	206 (5,232 mm)	17.5-20 (5,334-6,096 mm)	160-174 C.T. (4,064-4,420 mm)
190-24-40	61.75 (1,568 mm)	40,000 (18,144 kg)	223 (5,664 mm)	19-21.5 (5,791-6,553 mm)	174-190 C.T. (4,420-4,826 mm)
138-18-52	61.75 (1,568 mm)	52,000 (23,587 kg)	176 (4,470 mm)	15-17.5 (4,572-5,334 mm)	138-144 C.T. (3,505-3,658 mm)
174-20-52	61.75 (1,568 mm)	52,000 (23,587 kg)	206 (5,232 mm)	17.5-20 (5,334-6,096 mm)	160-174 C.T. (4,064-4,420 mm)
190-24-52	61.75 (1,568 mm)	52,000 (23,587 kg)	223 (5,664 mm)	19-21.5 (5,791-6,553 mm)	174-190 C.T. (4,420-4,826 mm)
138-18-65	61.75 (1,568 mm)	65,000 (29,484 kg)	174 (4,420 mm)	15-17.5 (4,572-5,334 mm)	138-144 C.T. (3,505-3,658 mm)
174-20-65	61.75 (1,568 mm)	65,000 (29,484 kg)	206 (5,232 mm)	17-20 (5,182-6,096 mm)	160-174 C.T. (4,064-4,420 mm)
190-24-65	61.75 (1,568 mm)	65,000 (29,484 kg)	223 (5,664 mm)	19-21.5 (5,791-6,553 mm)	174-190 C.T. (4,420-4,826 mm)



\* This data is for reference purposes only, and is not intended to replace a properly calculated weight distribution.

Your local distributor:

**STELLAR**  
INDUSTRIES INC.  
Our People. Our Products.

190 State Street  
P.O. Box 169  
Garner, IA 50438  
Telephone: (641) 923-3741 • (800) 321-3741  
Fax: (641) 923-2812  
Internet: [www.stellarindustries.com](http://www.stellarindustries.com)  
Email: [sales@stellarindustries.com](mailto:sales@stellarindustries.com)

Government specifications available.

\* All specifications are subject to change without notification.

For the most up to date version of this brochure, please visit [www.stellarindustries.com](http://www.stellarindustries.com).

An Employee Owned Company.  
Copyright © 2017 Stellar Industries, Inc.

STL000083 1/19