

# Load Rating Chart

## *Model SC97*



© Manitex

---

**NOTE:** *Additional copies of this Load Rating Chart can be purchased from your Manitex Distributor. When ordering, use the part number shown in the bottom left corner of this page.*

**RANGE DIAGRAM  
- FOR CRANE OPERATION ONLY -  
(MEETS ANSI B30.5 REQUIREMENTS)**

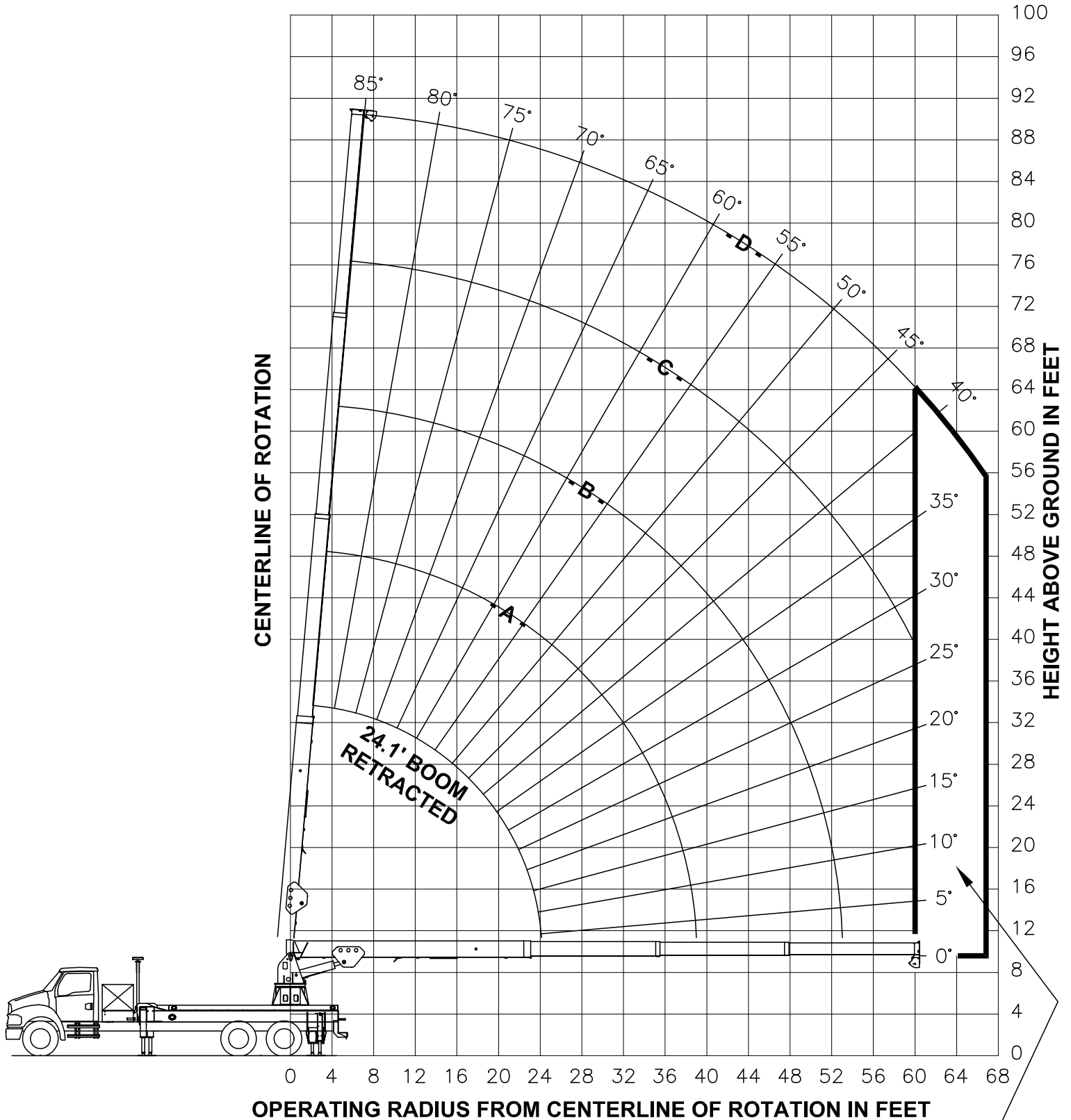

**DO NOT EXTEND  
BOOM INTO  
THIS AREA**

# LOAD CHART

## -FOR CRANE APPLICATION ONLY-

(MEETS ANSI B30.5 REQUIREMENTS)

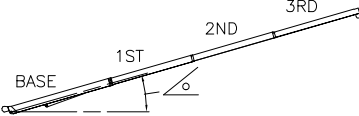
MAIN BOOM LOAD RATINGS IN LBS										
OPERATING RADIUS IN FT	LOADED BOOM ANGLE		BOOM LENGTH AND MARKER							
	°	24.1 FT	°	39 FT	°	53 FT	°	67 FT	°	81.1 FT
8	73	6000	80	6000	83	5500				
10	68	6000	77	6000	81	5270	83	4000		
12	63	6000	74	5520	78	5050	81	4000	84	3200
14	57	5690	71	5250	76	4820	80	3960	82	3100
16	51	5380	68	4990	74	4600	78	3800	81	3010
18	44	5070	64	4720	72	4370	76	3640	79	2910
20	37	4760	61	4450	69	4150	74	3480	77	2820
24	9	4150	54	3920	64	3700	71	3160	75	2630
28			46	3230	60	3250	67	2840	72	2440
32			37	2800	54	2800	63	2520	69	2250
36			24	2200	49	2350	59	2200	66	2060
40					42	1900	55	1880	63	1870
44					35	1500	51	1590	59	1680
48					27	1160	46	1250	56	1350
52					13	870	41	970	52	1070
56							35	750	48	820
60							28	530	44	600
65										

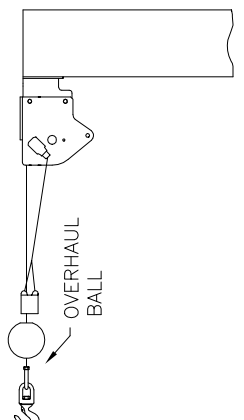
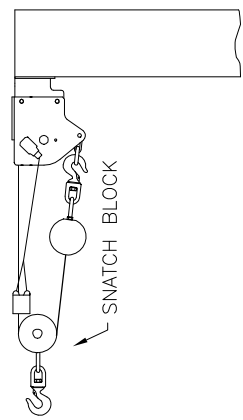
<b>ALLOWABLE LINE PULL</b>		<b>WARNING</b>
1 PART LINE	2 PART LINE	
		<p>ANTI-TWO BLOCK SYSTEM, IF SUPPLIED, MUST BE IN GOOD OPERATING CONDITION BEFORE OPERATING THE CRANE.</p> <p>REFER TO THE OWNER'S MANUAL.</p> <p>KEEP AT LEAST 3 WRAPS OF LOAD LINE ON THE DRUM AT ALL TIMES.</p>
4000 LBS	6000 LBS	

**DEDUCTIONS FROM RATED LOADS FOR LOAD HANDLING DEVICES SUPPLIED BY MANITEX**

OVERHAUL WEIGHT — — — — —	80 LBS
SNATCH BLOCK — — — — —	40 LBS
2—MANBASKET SLR PLATFORM — — — — —	700 LBS

**WARNING**

1. THE OPERATOR MUST READ AND UNDERSTAND THE OWNER'S MANUAL BEFORE OPERATING THIS CRANE.
2. POSITIONING OR OPERATION OF CRANE BEYOND AREAS SHOWN ON THIS CHART IS NOT INTENDED OR APPROVED EXCEPT WHERE SPECIFIED IN OWNER'S MANUAL.
3. LOADED BOOM ANGLES AT SPECIFIED BOOM LENGTHS GIVE ONLY AN APPROXIMATION OF THE OPERATING RADIUS. THE BOOM ANGLE BEFORE LOADING SHOULD BE GREATER TO ACCOUNT FOR DEFLECTIONS. DO NOT EXCEED THE OPERATING RADIUS FOR RATED LOADS.
4. FOR BOOM ANGLES NOT SHOWN ON LOAD RATING CHART, USE RATING OF NEXT LOWER BOOM ANGLE.
5. FOR BOOM LENGTHS NOT SHOWN, USE RATING OF NEXT SHORTER OR LONGER BOOM LENGTH, WHICHEVER IS LESS. FOR RADII NOT SHOWN, USE RATING OF NEXT LONGER RADIUS.
6. CRANE LOAD RATINGS ON OUTRIGGERS ARE BASED ON FREELY SUSPENDED LOADS WITH THE MACHINE LEVELED AND STANDING ON A FIRM UNIFORM SUPPORTING SURFACE. NO ATTEMPT SHALL BE MADE TO MOVE A LOAD HORIZONTALLY ON THE GROUND IN ANY DIRECTION.
7. PRACTICAL WORKING LOADS DEPEND ON SUPPORTING SURFACE, WIND, AND OTHER FACTORS AFFECTING STABILITY SUCH AS HAZARDOUS SURROUNDINGS, EXPERIENCE OF PERSONNEL, AND PROPER HANDLING, ALL OF WHICH MUST BE TAKEN INTO ACCOUNT BY THE OPERATOR.
8. THE MAXIMUM LOAD WHICH MAY BE TELESCOPED IS LIMITED BY HYDRAULIC PRESSURE, BOOM ANGLE, AND BOOM LUBRICATION. IT IS SAFE TO ATTEMPT TO TELESCOPE ANY LOAD WITHIN THE LIMITS OF THE LOAD RATING CHART.

**INFORMATION**

1. DEDUCTIONS MUST BE MADE FROM RATED LOADS FOR OPTIONAL ATTACHMENTS, HOOKS, AND LOADBLOCKS (SEE DEDUCTION CHART). WEIGHTS OF SLINGS AND ALL OTHER LOAD HANDLING DEVICES SHALL BE CONSIDERED A PART OF THE LOAD.
2. CRANE LOAD RATINGS WITH OUTRIGGERS ARE BASED ON OUTRIGGERS AND STABILIZERS EXTENDED AND SET WITH MACHINE LEVELED.
3. LOAD RATINGS ABOVE THE HEAVY LINE ARE STRUCTURALLY LIMITED CAPACITIES. LOAD RATINGS BELOW THE HEAVY LINE ARE STABILITY LIMITED CAPACITIES AND DO NOT EXCEED 85% OF TIPPING.

**DEFINITIONS**

1. OPERATING RADIUS IS THE HORIZONTAL DISTANCE FROM THE AXIS OF ROTATION TO THE CENTER OF THE VERTICAL HOIST LINE OR TACKLE WITH LOAD APPLIED.
2. LOADED BOOM ANGLE AS SHOWN IN THE COLUMN HEADED BY  $\angle$ , IS THE INCLUDED ANGLE BETWEEN THE HORIZONTAL AND LONGITUDINAL AXES OF THE BOOM BASE AFTER LIFTING RATED LOAD AT RATED RADIUS.

# MODEL SC97

## SELF LEVELING ROTATING (SLR) PERSONNEL PLATFORM RANGE DIAGRAM

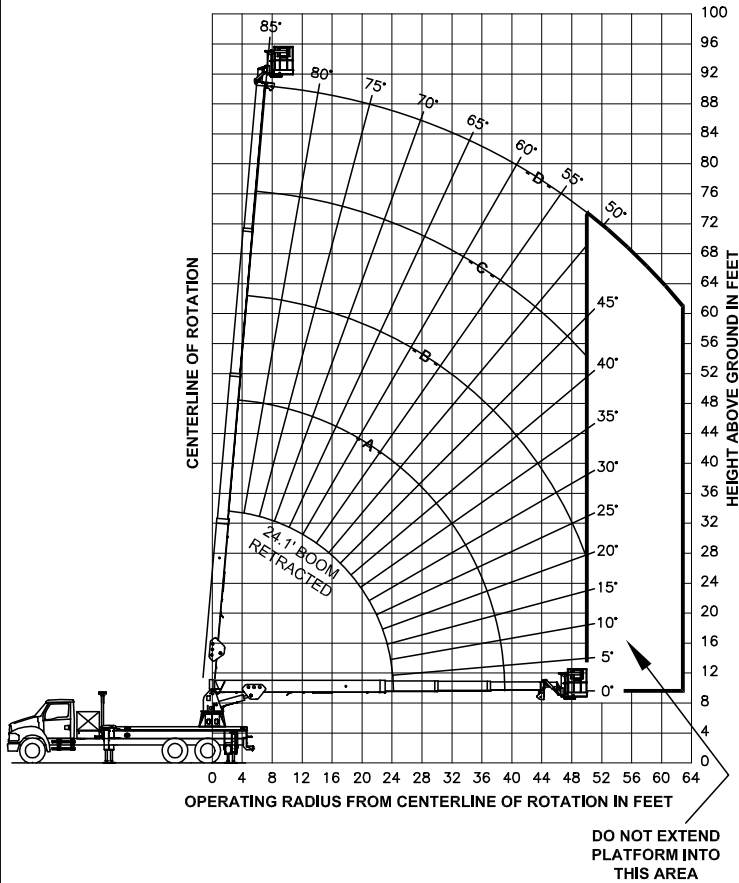

### AREA OF OPERATION

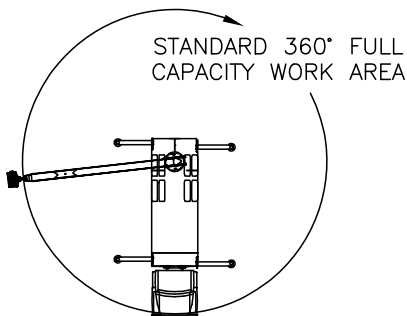

**Manitex**  
**SkyCrane**

CRANE MEETS ANSI A92.2 REQUIREMENTS

**! DANGER**

FAILURE TO READ, UNDERSTAND AND OBEY THE FOLLOWING INSTRUCTIONS CAN RESULT IN DEATH OR SERIOUS INJURY

**MAXIMUM ALLOWABLE PLATFORM CAPACITY IS 600 LBS.**

1. FOR CRANE STABILITY, LEVEL CRANE BY PROPERLY EXTENDING OUTRIGGERS ON A FIRM SURFACE. CRANE TIRES MUST BE JUST TOUCHING SURFACE.
2. THE MAXIMUM ALLOWABLE PLATFORM CAPACITY INCLUDES PERSONNEL, TOOLS, LOAD SUSPENDED FROM THE JIB WINCH OR ANY OTHER EXTERNAL WEIGHT.  
THE MAXIMUM ALLOWABLE PLATFORM CAPACITY MUST NEVER BE EXCEEDED. LOADS IN EXCESS OF THE MAXIMUM ALLOWABLE PLATFORM CAPACITY WILL AFFECT THE CRANE STABILITY OR STRUCTURAL INTEGRITY AND MAY CAUSE A FALL RESULTING IN DEATH OR SERIOUS INJURY.
3. ALWAYS USE BODY BELTS AND LANYARDS WHEN USING ANY PERSONNEL PLATFORM. FASTEN LANYARD HOOK TO ANCHOR POINT PROVIDED.
4. ALWAYS REMOVE OVERHAUL BALL OR SNATCH BLOCK AND SECURE LOAD LINE AT BOOM BASE ATTACHMENT BEFORE USING ANY PERSONNEL PLATFORM.
5. ANY PERSONNEL PLATFORM ON THIS MACHINE DOES NOT PROVIDE PROTECTION FROM CONTACT WITH OR PROXIMITY TO ELECTRICALLY CHARGED CONDUCTORS. DEATH OR SERIOUS INJURY WILL OCCUR IF ADEQUATE CLEARANCE IS NOT MAINTAINED.  
REFER TO OPERATORS MANUAL FOR MINIMUM CLEARANCE REQUIRED BETWEEN ANY PART OF THE BOOM OR PLATFORM AND THE POWER LINE.
6. WHEN LOADING OR UNLOADING ANY PERSONNEL, FULLY RETRACT BOOM, THEN LOWER BOOM AND EXTEND IF NECESSARY UNTIL PLATFORM IS CLOSE TO THE GROUND.