



# GR-1000XLL-4

100 Ton (90.7 Metric Ton) Capacity

Form NO. GR-1000-4-00102/US-02

## HYDRAULIC ROUGH TERRAIN CRANE

### DIMENSIONS

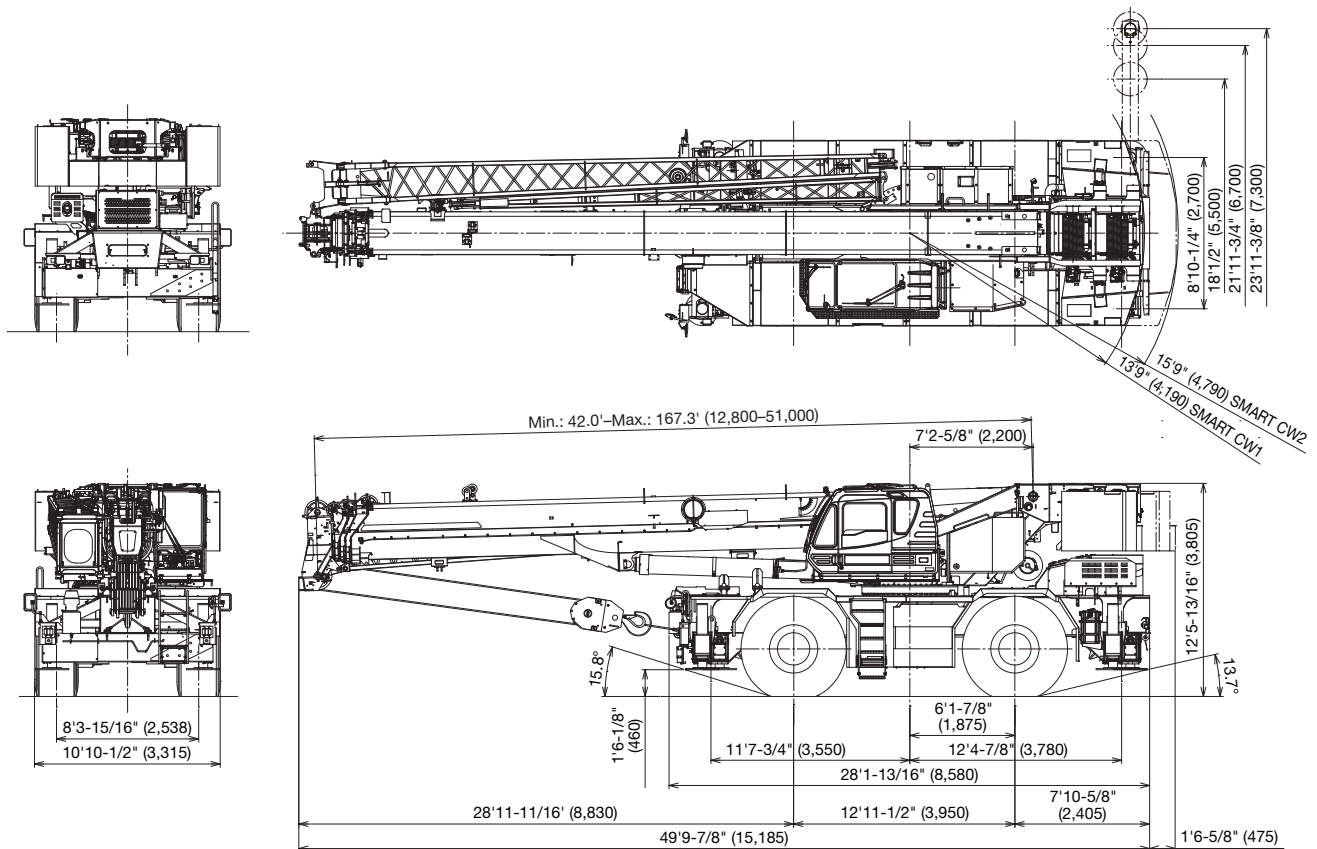

Note: Dimension is with boom angle at -1.5 degree.  
( ) Reference dimensions in mm.

### GENERAL DIMENSIONS

|                                | Feet        | Meters |                | Feet                 | Meters |
|--------------------------------|-------------|--------|----------------|----------------------|--------|
| Turning radius (29.5-25 Tires) |             |        | Overall length | approx. 49' 9-7/8"   | 15.185 |
| 4 wheel steer                  | 22' 4"      | 6.8    | Overall width  | approx. 10' 10-1/2"  | 3.315  |
| 2 wheel steer                  | 35' 9-3/32" | 10.9   | Overall height | approx. 12' 5-13/16" | 3.805  |

# CRANE SPECIFICATIONS

## BOOM

5 section full power synchronized telescoping boom, 42.0'-167.3' (12.8 m-51.0 m), of round box construction with 7 sheaves, 17-5/16" (0.44 m) root diameter, at boom head.

The synchronization system consists of 2 telescope cylinders, an extension cable and retraction cable. Hydraulic cylinder fitted with holding valve. 2 easily removable wire rope guards, rope dead end provided on both sides of boom head. Boom telescope sections are supported by wear pads both vertically and horizontally. Extension speed 125.3' in 170 seconds.

**BOOM ELEVATION** - By a double acting hydraulic cylinder with holding valve. Elevation -1.5°-80.5°, combination controls for hand or foot operation. Boom angle indicator. Automatic speed reduction and slow stop function. Boom raising speed 20° to 60° in 46 seconds.

**JIB** - 2 stage bi-fold lattice type, 3.5°, 25° or 45° offset (tilt type). Single sheave, 15-5/8" (0.396 m) root diameter, at the head of both jib sections. Stored alongside base boom section. Jib length is 33.2' (10.1 m) or 58.1' (17.7 m). Assistant cylinders for mounting and stowing, controlled at right side of superstructure. Self stowing jib mounting pins.

## AUXILIARY LIFTING SHEAVE (SINGLE TOP)

Single sheave, 15-5/8" (0.396 m) root diameter. Mounted to main boom head for single line work (stowable).

**ANTI-TWO BLOCK** - Pendant type over-winding cut out device with audio-visual (FAILURE lamp/BUZZER) warning system.

## SLEWING

Hydraulic axial piston motor through planetary slewing speed reducer. Continuous 360° full circle slewing on ball bearing turn table at 1.5 min<sup>-1</sup> {rpm}. Equipped with manually locked/released slewing brake. A 360° positive slewing lock for pick and carry and travel modes, manually engaged in cab. Twin slewing system: Free slewing or lock slewing controlled by selector switch on front console.

## WINCH

**MAIN WINCH** - Variable speed type with grooved drum driven by hydraulic axial piston motor through speed reducer. Power load lowering and raising. Equipped with automatic brake (neutral brake) and counterbalance valve. Controlled independently of auxiliary winch. Equipped with cable follower and drum rotation indicator.

**DRUM** - Grooved 14-1/4" (0.362 m) root diameter x 26-13/16" (0.681 m) wide. Wire rope: 935' of 3/4" diameter rope (285 m of 19 mm). Drum capacity: 1135' (346 m) 7 layers. Maximum single line pull: 1st layer 20,000 lbs (9,090 kg). Maximum permissible line pull wire strength: 14,600 lbs (6,600 kg).

**AUXILIARY WINCH** - Variable speed type with grooved drum driven by hydraulic axial piston motor through speed reducer. Power load lowering and raising. Equipped with automatic brake (neutral brake) and counterbalance valve. Controlled independently of main winch. Equipped with cable follower and drum rotation indicator.

**DRUM** - Grooved 14-1/4" (0.362 m) root diameter x 26-13/16" (0.681 m) wide. Wire rope: 482' of 3/4" diameter rope (147 m of 19 mm). Drum capacity: 1135' (346 m) 7 layers. Maximum single line pull: 1st layer 20,000 lbs (9,090 kg). Maximum permissible line pull wire strength: 14,600 lbs (6,600 kg).

**WIRE ROPE** - Non-rotating 3/4" (19 mm) P·S (19) + 39 x P·7 Breaking Strength 72,800 lbs (33,000 kg)

## HOOK BLOCKS

100 ton (90.7 metric ton)-8 sheaves with swivel hook and safety latch, for 3/4" (19 mm) wire rope.

7.3 ton (6.6 metric ton) - Weighted hook with swivel and safety latch, for 3/4" (19 mm) wire rope.

## COUNTERWEIGHT

Self-removable counterweight ..... 24,700 lbs (11,200 kg)

## HYDRAULIC SYSTEM

**PUMPS** - 2 variable piston pumps for crane functions. Tandem gear pump for steering slewing and other hydraulic systems. Powered by carrier engine. Pump disconnect for crane is engaged/disengaged by rotary switch from operator's cab.

**CONTROL VALVES** - Multiple valves actuated by pilot pressure with integral pressure relief valves.

**RESERVOIR** - 210 gallon (795 lit.) capacity. External sight level gauge.

**FILTRATION** - BETA10=10 return filter, full flow with bypass protection, located inside of hydraulic reservoir. Accessible for easy replacement.

**OIL COOLER** - Air cooled fan type.

## CAB AND CONTROLS

Both crane and drive operations can be performed from one cab mounted on rotating superstructure.

20° tilt, Left side, 1 man type, steel construction with sliding door access and safety glass windows opening at side. Door window is powered control. Windshield glass window and roof glass window are shatter-resistant. Tilt-telescoping steering wheel. Adjustable control lever stands for slewing, boom elevating, boom telescoping, auxiliary winch and main winch. Control lever stands can change neutral positions and tilt for easy access to cab. 3 way adjustable operator's seat with high back, headrest and armrest. Engine throttle knob. Foot operated controls: boom elevating boom telescoping, service brake and engine throttle. Hot water cab heater and air conditioning.

Dash-mounted Instrument panel, Multi Function Display, Starter switch (engine start/stop), 12 V power outlet, USB port, drive selector switch, parking brake switch, steering mode select switch, power window switch, pump engaged/disengaged switch, slewing brake switch, telescoping/auxiliary winch select switch, outrigger controls, free slewing/lock slewing selector switch, air conditioning control switch.

Instruments panel - Torque converter oil temperature, engine water temperature, air pressure, fuel, speedometer, tachometer, hour meter and odometer/tripmeter.

Multi Function Display - DEF level gauge, Fuel consumption monitor.

Tadano electronic LOAD MOMENT INDICATOR system (AML-E2) including:

- Control lever lockout function with audible and visual pre-warning
- Number of parts of line
- Boom position indicator
- Outrigger state indicator
- Slewing angle
- Boom angle / boom length / jib offset angle / jib length / load radius / rated lifting capacities / actual loads read out
- Potential lifting height
- Ratio of actual load moment to rated load moment indication
- Automatic Speed reduction and slow stop function on boom elevation and slewing
- Working condition register switch
- Load radius / boom angle / tip height / slewing range preset function
- External warning lamp
- Tare function
- Main Hydraulic oil pressure
- Fuel consumption monitor

- Main winch / auxiliary winch select
- Drum rotation indicator (audible and visible type) main and auxiliary winch
- On rubber indicator

TADANO AML-E2 monitors outrigger extended length and automatically programs the corresponding "RATED LIFTING CAPACITIES" table.

Operator's right hand console includes transmission gear selector, slewing lock lever and sight level bubble.

Upper console includes, roof washer and wiper switch, emergency outrigger set up key switch, jib equipped / removed select switch, high speed winch (main / aux) switch, Cab tilt switch, Pump disconnect enable switch and boom emergency telescoping switch (2nd and 3rd-top).

NOTE: Each crane motion speed is based on unladen conditions.

**BRAKE SYSTEMS** - Service: Air over hydraulic disc brakes on all 4 wheels. Parking / Emergency: Spring applied-air released brake acting on input shaft of front axle. Auxiliary: Electro-pneumatic operated exhaust brake.

**TIRES** - 29.5-25 36PR (OR) Air pressure: 68 psi (470 kPa)  
29.5-25 40PR (OR) Air pressure: 67 psi (465 kPa)

**OUTRIGGERS**- Four hydraulic, beam and jack outriggers. Vertical jack cylinders equipped with integral holding valve. Each outrigger beam and jack is controlled independently from cab. Beams extend to 23' 11-3/8" (7.3 m) center-line and retract to within 10' 10-1/2" (3.315 m) overall width with floats. Outrigger jack floats are attached thus eliminating the need of manually attaching and detaching them. Controls and sight bubble located in superstructure cab. Four outrigger extension lengths are provided with corresponding "RATED LIFTING CAPACITIES" for crane duty in confined areas.

Min. Extension 8' 10-1/4" (2.7 m) center to center  
Mid. Extension 18' 1/2" (5.5 m) center to center  
Mid. Extension 21' 11-3/4" (6.7 m) center to center  
Max. Extension 23' 11-3/8" (7.3 m) center to center

Float size (Diameter) 1' 11- 5/8" (0.6 m)

**GRADEABILITY**( tanθ ) - 84% (at stall), \*\*57%  
\*\* Machine should be operated within the limit of engine design (30°: Cummins B6.7)

## CARRIER SPECIFICATIONS

**TYPE** - Rear engine, left hand steering, driving axle 2-way selected type by manual switch, 4 x 2 front drive, 4 x 4 front and rear drive.

**FRAME** - High tensile steel, all welded mono-box construction.

**TRANSMISSION** - Electronically controlled full automatic transmission. Torque converter driving full powershift with driving axle selector. 6 forward and 2 reverse speeds, constant mesh.

3 speeds - high range - 2 wheel drive; 4 wheel drive  
3 speeds - low range - 4 wheel drive

**TRAVEL SPEED** - 22 mph (36 km/h)

**AXLE** - Front: Full floating type, steering and driving axle with planetary reduction. Rear: Full floating type, steering and driving axle with planetary reduction and non-spin rear differential.

**STEERING** - Hydraulic power steering controlled by steering wheel. Four steering modes available: 2 wheel front, 2 wheel rear, 4 wheel coordinated and 4 wheel crab.

**SUSPENSION** - Front: Rigid mounted to frame. Rear: Pivot mounted with hydraulic lockout device.

### ENGINE

|                               |   |
|-------------------------------|---|
| Model                         | Cummins B6.7                              |
| Type                          | Direct injection diesel                   |
| No. of cylinders              | 6   |
| Combustion                    | 4 cycle, turbo charged and after cooled   |
| BoreXStroke, in. (mm)         | 4.212 X 4.882 (107 X 124)                 |
| Displacement, cu. in (liters) | 409 (6.7)                                 |
| Air inlet heater              | 24 volt preheat                           |
| Air cleaner                   | Dry type, replaceable element             |
| Oil filter                    | Full flow with replaceable element        |
| Fuel filter                   | Full flow with replaceable element        |
| Fuel tank, gal. (liters)      | 79.2 (300), right side of carrier         |
| Cooling                       | Liquid pressurized, recirculating by-pass |

|                               |  |
|-------------------------------|--|
| Radiator                      | Fin and tube core, thermostat controlled |
| Fan, in. (mm)                 | Suction type, 9-blade, 28 (711) dia.     |
| Starting                      | 24 volt                                  |
| Charging                      | 24 volt system, negative ground          |
| Battery                       | 2-120 amp. Hour                          |
| Compressor, air, CFM (l /min) | 17.0 CFM (481) at 2,400 rpm              |
| Output, Max. HP (kW)          | Gross 280 (209) at 2,200 rpm             |
| Torque, Max. ft-lb (Nm)       | 850 (1,152) at 1,500 rpm                 |
| Capacity, gal. (liters)       |  |
| Cooling water                 | 2.7 (10)                                 |
| Lubrication                   | 4.0 (15)                                 |
| Fuel                          | 79.2 (300)                               |
| DEF/AdBlue                    | 15.0 (57)                                |

# STANDARD EQUIPMENT

- 5 section full power partially synchronized boom  
42.0'-167.3' (12.8 m-51.0 m)
- 33.2' or 58.1' (10.1 m or 17.7 m) bi-fold lattice jib (tilt type)  
with 3.5°, 25° or 45° pinned offsets and self storing pins.
- Quick reeving type bi-fold jib
- Anti-Two block device (overwind cutout)
- Winch drum camera with light
- LED work lights
- Variable speed main winch with grooved drum, cable follower, drum  
rotation indicator (audible, visible and thumper type) and 935' of 3/4" cable.
- Variable speed auxiliary winch with grooved drum, cable follower, drum  
rotation indicator (audible, visible and thumper type) and 482' of 3/4" cable.
- Auxiliary lifting sheave (single top) stowable
- 2-speed winch
- 100 ton (90.7 metric ton) hook block - 8 sheave with swivel hook  
and safety latch for 3/4" (19 mm) wire rope
- 7.3 ton (6.6 metric ton) hook with swivel
- Tadano twin slewing system and 360° positive slewing lock
- Positive control
- Hydraulic oil cooler
- 3 way adjustable cloth seat with armrests, high back and seat belt
- Tilt-telescoping steering wheel
- Tinted safety glass and sun visor
- Front windshield wiper and washer
- Roof window wiper and washer
- Power window (cab door)
- 12V power outlet
- Ashtray
- Cab floor mat
- Pump disconnect in operator's cab
- Air conditioner (hot water heater and cooler)
- Full instrumentation package
- Self centering finger control levers with pilot control
- Control pedals for boom elevating and boom telescoping
- Low oil pressure / high water temp. warning device (visual)
- Air cleaner dust indicator
- Cup holder
- Battery disconnect
- USB port
- 20° tilt cab
- Wind speed indicator
- Emergency steering system
- Tadano electronic load moment indicator system (AML-E2)
- Boom angle indicator
- Outrigger extension length detector
- Electronic crane monitoring system
- Rear view camera
- Right front view camera
- Fenders
- Air dryer
- Complete highway light package
- Towing hooks-Front and rear
- Hook block tie down (front bumper)
- Weighted hook storage compartment
- Halogen head lamp
- Independently controlled outriggers
- Four outrigger extension positions
- Self-storing outrigger pads
- Electronic controlled automatic transmission driven by torque converter
- 4 X 4 X 4 drive / steer
- Non-spin rear differential
- Automatic rear axle oscillation lockout system
- 29.5-25 36 PR tires
- 29.5-25 40 PR tires
- Disc brakes
- Water separator with filter (high filtration)
- Back-up alarm
- 24 volt electric system
- Tool storage compartment
- Tire inflation kit
- Cummins B6.7 turbo charged  
after cooled engine (280 HP) with exhaust brake
- Engine over-run alarm
- Lifting eyes
- Telematics (machine data logging and monitoring system)  
with HELLO-NET via internet (availability depends on countries)
- Fuel consumption monitor
- Eco mode system
- Self-removable counterweight
- Radiator cover
- Clearance sonar (Rear side)
- Automatic pump disconnect
- Over unwinding prevention

# HOISTING PERFORMANCE

## LINE SPEEDS AND PULLS

| Layer            | Main or auxiliary hoist - 14'-1/4" (0.362 m) drum |       |       |       |                                   |       |        |       |
|------------------|---|-------|-------|-------|-----------------------------------|-------|--------|-------|
|                  | Line speeds <sup>1</sup>                          |       |       |       | Line pulls Available <sup>2</sup> |       |        |       |
|                  | Low   |       | High  |       | Low                               |       | High   |       |
|                  | F.P.M   | m/min | F.P.M | m/min | Lbs.                              | kgf   | Lbs.   | kgf   |
| 1st              | 278   | 84    | 387   | 118   | 20,000                            | 9,090 | 14,400 | 6,520 |
| 2nd              | 302   | 92    | 421   | 128   | 18,100                            | 8,230 | 13,000 | 5,900 |
| 3rd              | 327   | 99    | 456   | 139   | 16,600                            | 7,520 | 11,900 | 5,390 |
| 4th              | 352   | 107   | 491   | 149   | 15,300                            | 6,920 | 10,900 | 4,960 |
| 5th              | 377   | 115   | 526   | 160   | 14,100                            | 6,410 | 10,100 | 4,600 |
| 6th              | 402   | 122   | 560   | 170   | 13,200                            | 5,970 | 9,400  | 4,280 |
| 7th <sup>3</sup> | 427   | 130   | 595   | 181   | 12,300                            | 5,590 | 8,800  | 4,010 |

- Maximum permissible line pull wire strength  
14,600 lbs (6,600 kg).

<sup>1</sup> Line speeds based only on hook block, not loaded.  
<sup>2</sup> Developed by machinery with each layer of wire rope, but not based  
on rope strength or other limitation in machinery or equipment.  
<sup>3</sup> Seventh layer of wire rope are not recommended  
for hoisting operations.

## DRUM WIRE ROPE CAPACITIES

| Wire rope layer | Main and auxiliary drum grooved lagging<br>3/4" (19 mm) wire rope |        |                   |        |
|-----------------|---|--------|-------------------|--------|
|                 | Rope per layer m  |        | Total wire rope m |        |
|                 | Feet  | Meters | Feet              | Meters |
| 1               | 128.0   | 39.0   | 128.0             | 39.0   |
| 2               | 139.4   | 42.5   | 267.4             | 81.5   |
| 3               | 150.9   | 46.0   | 418.3             | 127.5  |
| 4               | 162.1   | 49.4   | 580.4             | 176.9  |
| 5               | 173.9   | 53.0   | 754.3             | 229.9  |
| 6               | 185.4   | 56.5   | 939.6             | 286.4  |
| 7               | 196.9   | 60.0   | 1,136.5           | 346.4  |

## DRUM DIMENSIONS

|                        | Inch      | mm  |
|------------------------|-----------|-----|
| Root diameter          | 14-1/4"   | 362 |
| Length Flange diameter | 26-13/16" | 681 |
|                        | 25-7/8"   | 657 |

# GR-1000XLL-4 WORKING RANGE CHART

## SMART CW1 360° ROTATION

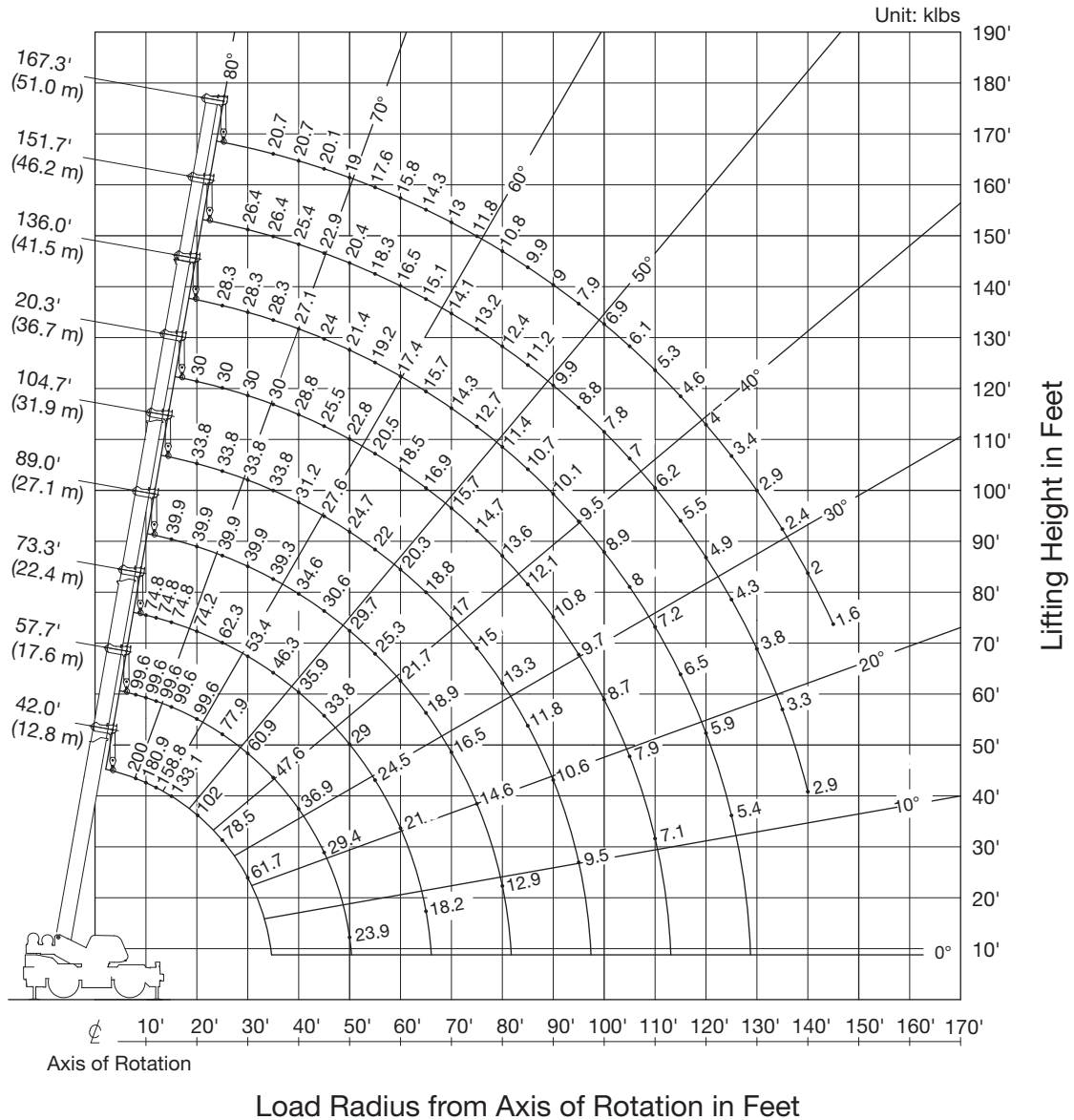

BOOM

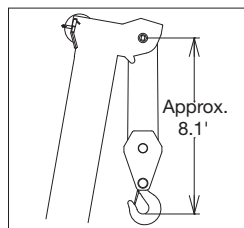

SINGLE TOP

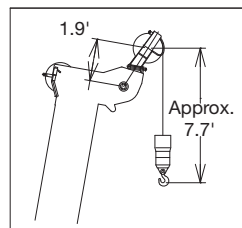

NOTE: Boom geometry shown is for unloaded condition and machine standing level on firm supporting surface. Boom deflection and subsequent radius and boom angle change must be accounted for when applying load to hook. When boom length is same as telescoping mode 1 and 2, it show large load.

# GR-1000XLL-4 WORKING RANGE CHART

## SMART CW2 360° ROTATION

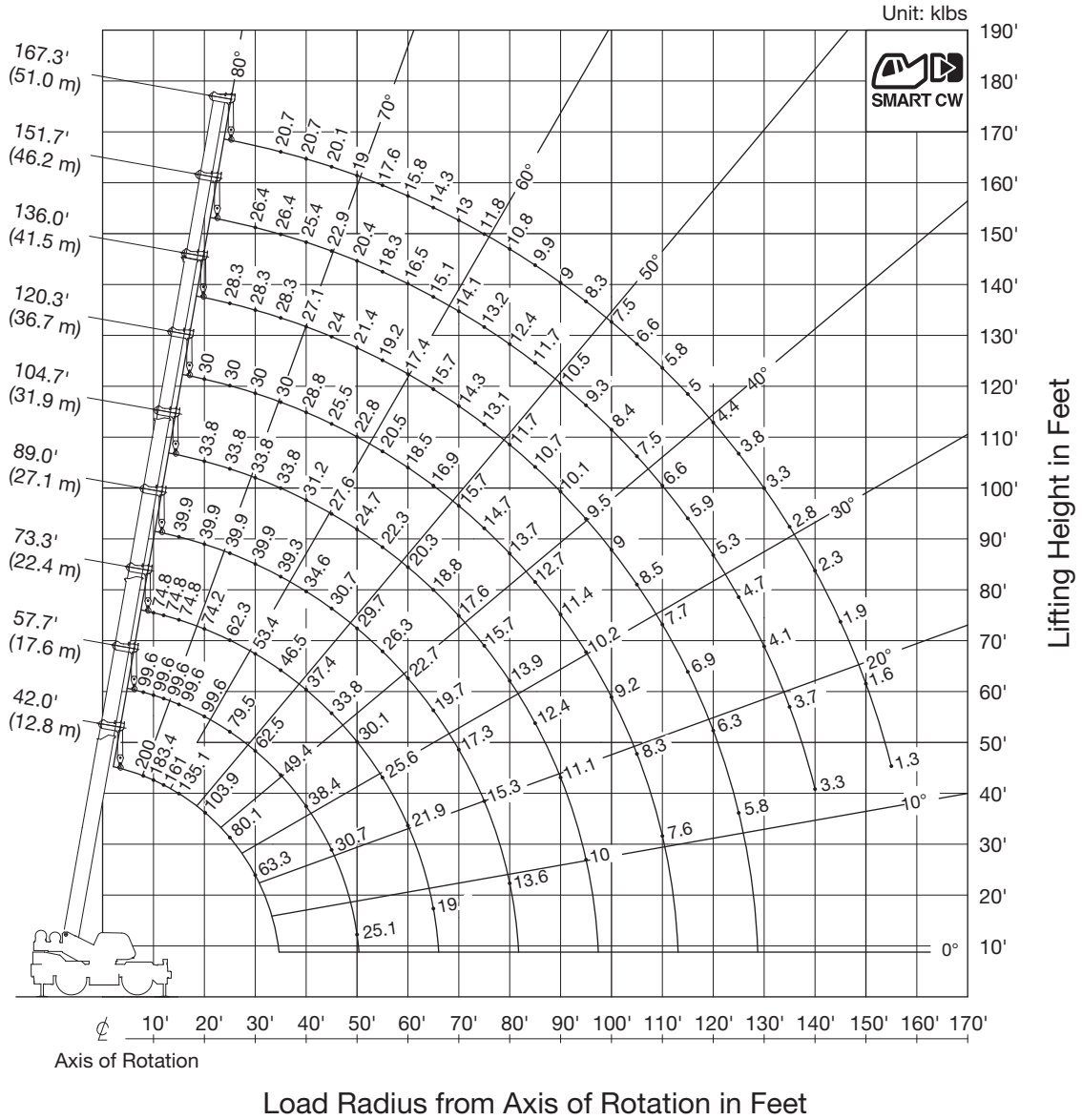

BOOM

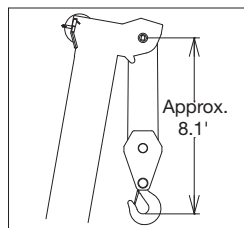

SINGLE TOP

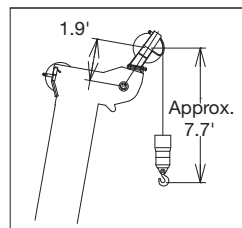

NOTE: Boom geometry shown is for unloaded condition and machine standing level on firm supporting surface. Boom deflection and subsequent radius and boom angle change must be accounted for when applying load to hook. When boom length is same as telescoping mode 1 and 2, it show large load.

# GR-1000XLL-4 WORKING RANGE CHART

## SMART CW2 SMART CHART

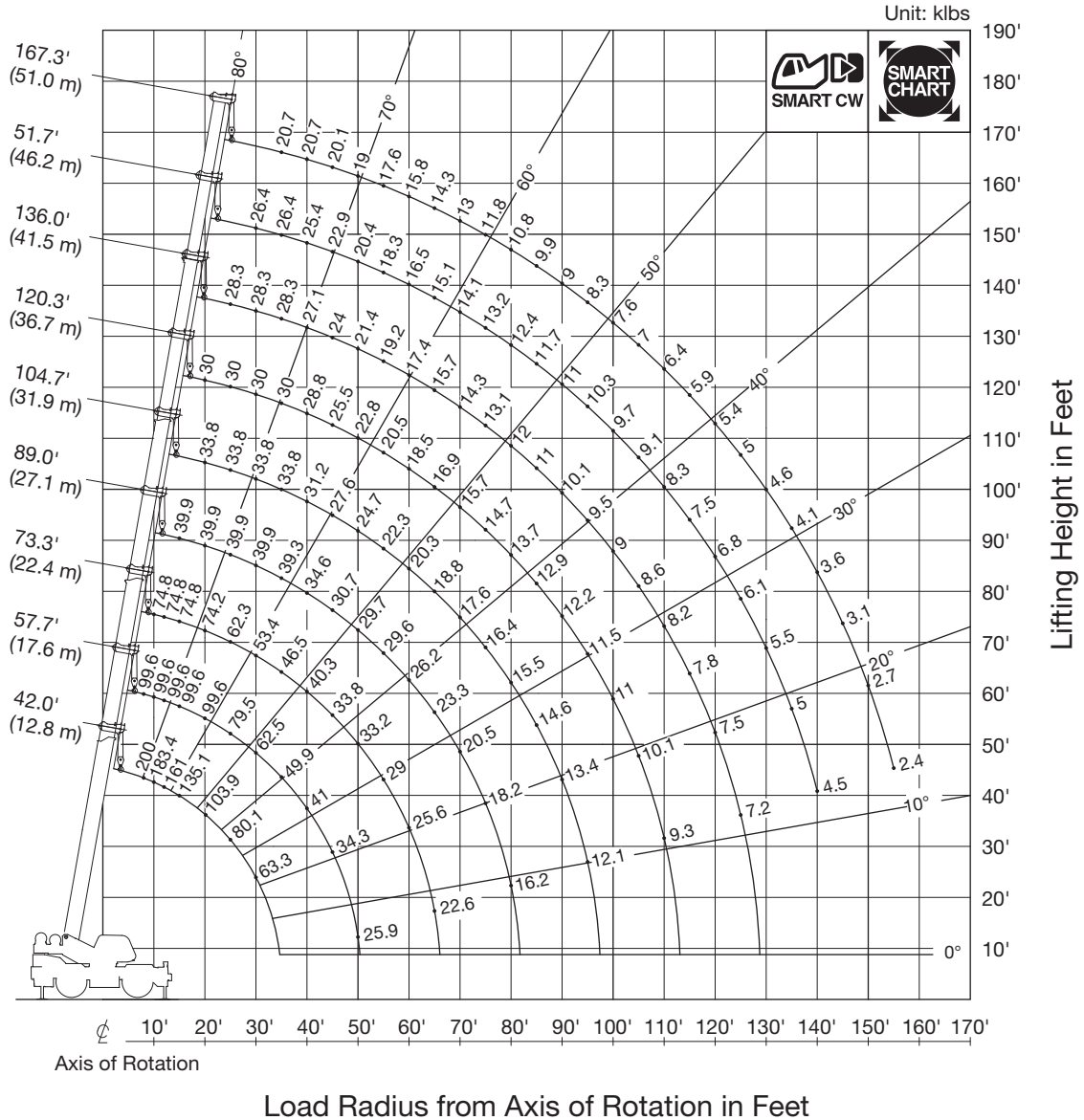

BOOM

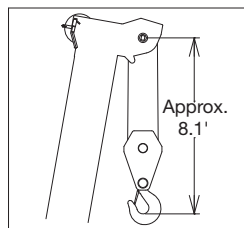

SINGLE TOP

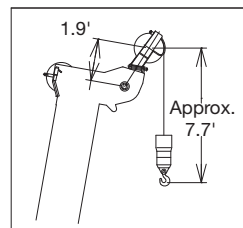

NOTE: Boom geometry shown is for unloaded condition and machine standing level on firm supporting surface. Boom deflection and subsequent radius and boom angle change must be accounted for when applying load to hook. When boom length is same as telescoping mode 1 and 2, it show large load.

# GR-1000XLL-4 WORKING RANGE CHART

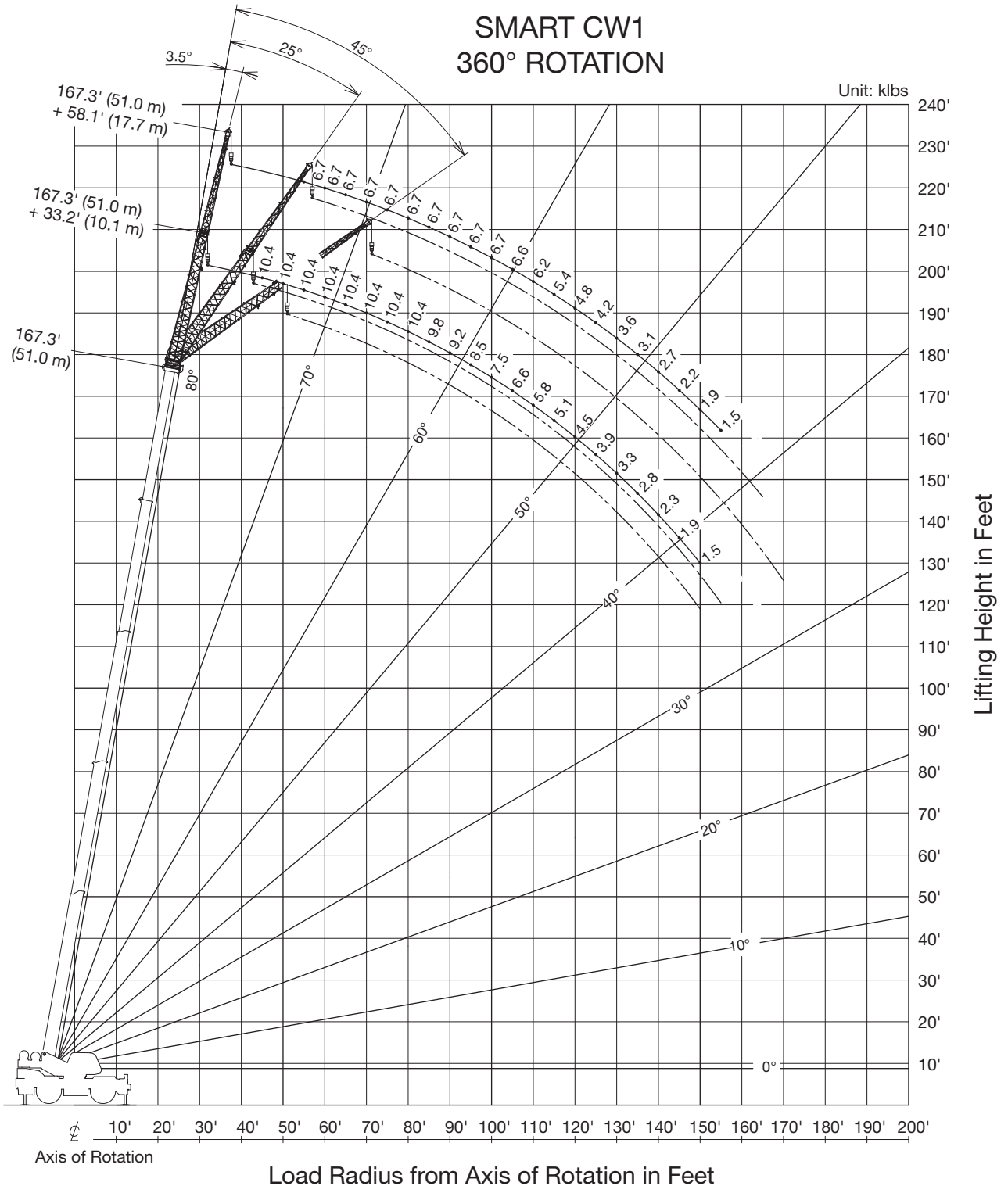

NOTE: Jib geometry shown are for unloaded condition and machine standing level on firm supporting surface. Boom deflection and subsequent radius and boom angle change must be accounted for when applying load to hook.

JIB

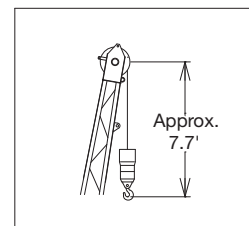



# GR-1000XLL-4 WORKING RANGE CHART

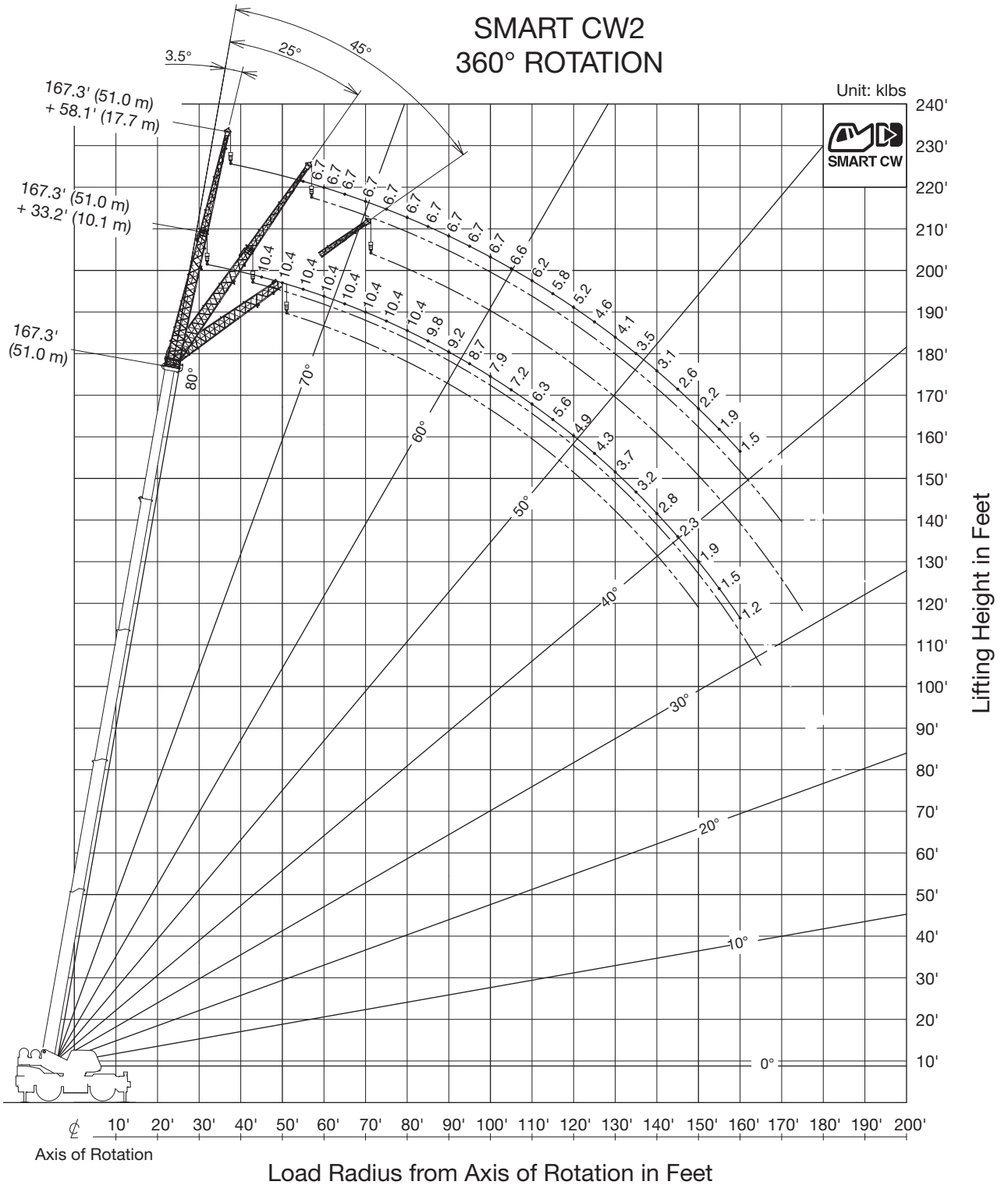

NOTE: Jib geometry shown are for unloaded condition and machine standing level on firm supporting surface. Boom deflection and subsequent radius and boom angle change must be accounted for when applying load to hook.

JIB

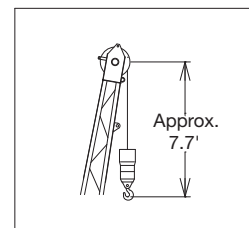

# GR-1000XLL-4 WORKING RANGE CHART

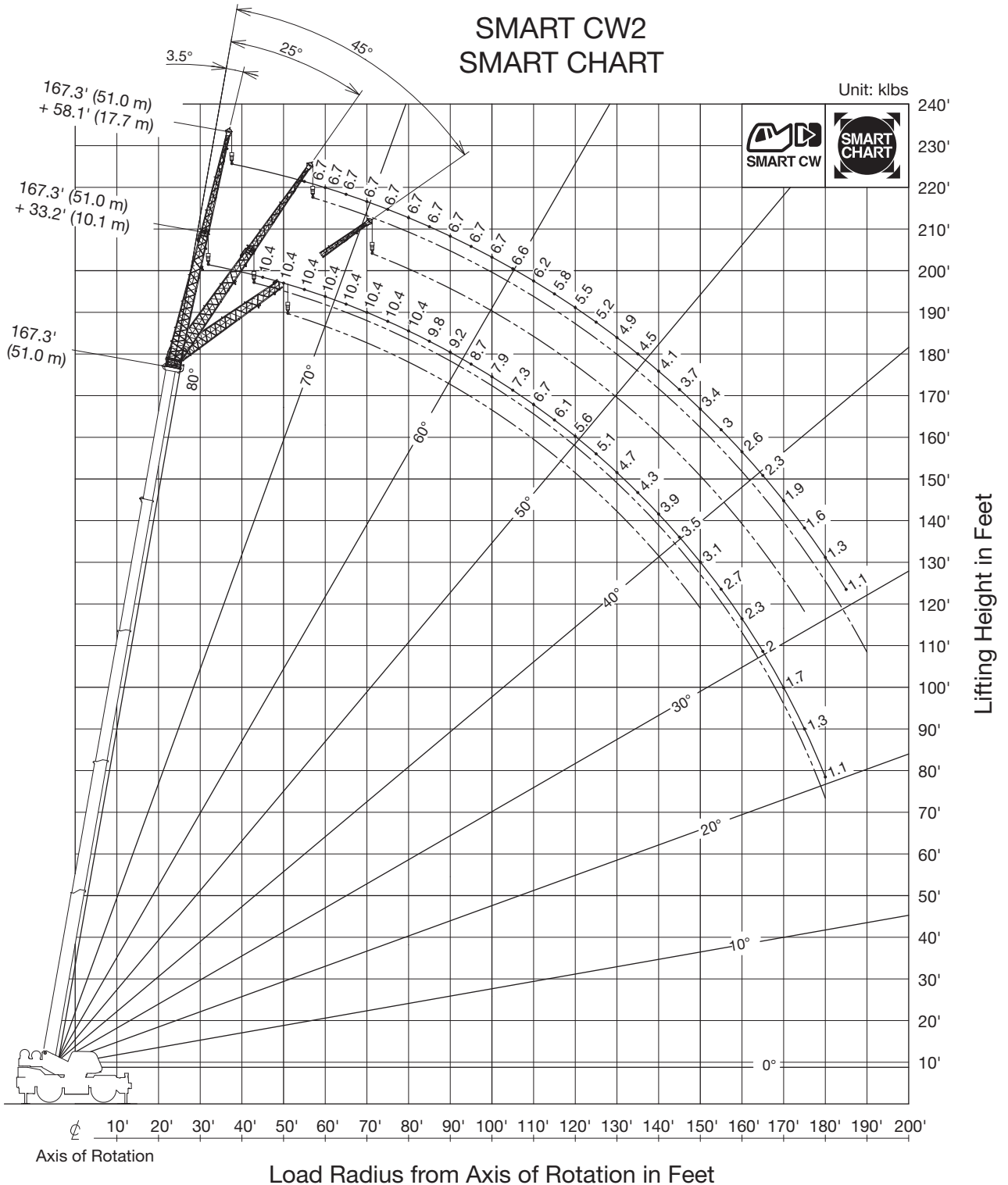

NOTE: Jib geometry shown are for unloaded condition and machine standing level on firm supporting surface. Boom deflection and subsequent radius and boom angle change must be accounted for when applying load to hook.

JIB

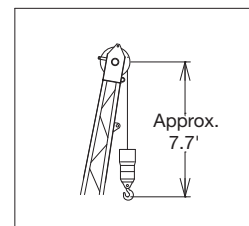

# GR-1000XLL-4 RATED LIFTING CAPACITIES (IN POUNDS)

| COUNTERWEIGHT 24,700lbs (11.2 t)<br>ON OUTRIGGERS FULLY EXTENDED 23' 11-3/8" (7.3 m) SPREAD<br>360° ROTATION<br>SMART CW1 |          |          |          |          |          |          |          |          |          |          |          |          |          |          |        |
|---|----------|----------|----------|----------|----------|----------|----------|----------|----------|----------|----------|----------|----------|----------|--------|
| B \ A   | 42.0'    | 57.7'    | 73.3'    |          | 89.0'    |          | 104.7'   |          | 120.3'   |          | 136.0'   |          | 151.7'   |          | 167.3' |
|   | (12.8 m) | (17.6 m) | (22.4 m) | (22.4 m) | (27.1 m) | (27.1 m) | (31.9 m) | (31.9 m) | (36.7 m) | (36.7 m) | (41.5 m) | (41.5 m) | (46.2 m) | (46.2 m) | (51 m) |
| 8   | 200,000  | 99,600   |          |          |          |          |          |          |          |          |          |          |          |          |        |
| 10  | 180,900  | 99,600   | 74,800   | 33,800   |          |          |          |          |          |          |          |          |          |          |        |
| 12  | 158,800  | 99,600   | 74,800   | 33,800   |          |          |          |          |          |          |          |          |          |          |        |
| 15  | 133,100  | 99,600   | 74,800   | 33,800   | 39,900   | 29,700   |          |          |          |          |          |          |          |          |        |
| 20  | 102,000  | 99,600   | 74,200   | 33,800   | 39,900   | 29,700   | 33,800   | 27,700   | 30,000   | 27,600   |          |          |          |          |        |
| 25  | 78,500   | 77,900   | 62,300   | 33,800   | 39,900   | 29,700   | 33,800   | 27,700   | 30,000   | 27,600   | 28,300   | 27,500   |          |          |        |
| 30  | 61,700   | 60,900   | 53,400   | 33,800   | 39,900   | 29,700   | 33,800   | 27,700   | 30,000   | 27,600   | 28,300   | 26,100   | 26,400   | 24,100   |        |
| 35  |          | 47,600   | 46,300   | 33,800   | 39,300   | 29,700   | 33,800   | 27,700   | 30,000   | 27,400   | 28,300   | 23,900   | 26,400   | 23,600   | 20,700 |
| 40  |          | 36,900   | 35,900   | 33,800   | 34,600   | 29,700   | 31,200   | 27,700   | 28,800   | 25,000   | 27,100   | 21,500   | 25,400   | 22,000   | 20,700 |
| 45  |          | 29,400   | 28,500   | 33,800   | 30,600   | 29,700   | 27,600   | 26,300   | 25,500   | 23,000   | 24,000   | 19,500   | 22,900   | 20,500   | 20,100 |
| 50  |          | 23,900   | 23,000   | 29,000   | 25,000   | 29,700   | 24,700   | 23,900   | 22,800   | 21,200   | 21,400   | 17,800   | 20,400   | 19,100   | 19,000 |
| 55  |          |          | 18,800   | 24,500   | 20,800   | 25,300   | 21,800   | 22,000   | 20,500   | 19,800   | 19,200   | 16,300   | 18,300   | 17,600   | 17,600 |
| 60  |          |          | 15,400   | 21,000   | 17,400   | 21,700   | 18,400   | 20,300   | 18,500   | 18,200   | 17,400   | 15,000   | 16,500   | 16,200   | 15,800 |
| 65  |          |          | 12,800   | 18,200   | 14,600   | 18,900   | 15,700   | 18,800   | 16,400   | 16,900   | 15,700   | 14,000   | 14,900   | 15,100   | 14,300 |
| 70  |          |          |          |          | 12,300   | 16,500   | 13,400   | 17,000   | 14,100   | 15,700   | 14,300   | 13,000   | 13,600   | 14,100   | 13,000 |
| 75  |          |          |          |          | 10,400   | 14,600   | 11,400   | 15,000   | 12,200   | 14,700   | 12,700   | 12,100   | 12,400   | 13,200   | 11,800 |
| 80  |          |          |          |          | 8,800    | 12,900   | 9,800    | 13,300   | 10,500   | 13,600   | 11,000   | 11,400   | 11,300   | 12,400   | 10,800 |
| 85  |          |          |          |          |          |          | 8,400    | 11,800   | 9,100    | 12,100   | 9,600    | 10,700   | 10,000   | 11,200   | 9,900  |
| 90  |          |          |          |          |          |          | 7,200    | 10,600   | 7,900    | 10,800   | 8,400    | 10,100   | 8,800    | 9,900    | 9,000  |
| 95  |          |          |          |          |          |          | 6,100    | 9,500    | 6,800    | 9,700    | 7,300    | 9,500    | 7,600    | 8,800    | 7,900  |
| 100   |          |          |          |          |          |          |          |          | 5,800    | 8,700    | 6,300    | 8,900    | 6,700    | 7,800    | 6,900  |
| 105   |          |          |          |          |          |          |          |          | 5,000    | 7,900    | 5,500    | 8,000    | 5,800    | 7,000    | 6,100  |
| 110   |          |          |          |          |          |          |          |          | 4,300    | 7,100    | 4,700    | 7,200    | 5,000    | 6,200    | 5,300  |
| 115   |          |          |          |          |          |          |          |          |          |          | 4,000    | 6,500    | 4,300    | 5,500    | 4,600  |
| 120   |          |          |          |          |          |          |          |          |          |          | 3,400    | 5,900    | 3,700    | 4,900    | 4,000  |
| 125   |          |          |          |          |          |          |          |          |          |          | 2,900    | 5,400    | 3,200    | 4,300    | 3,400  |
| 130   |          |          |          |          |          |          |          |          |          |          |          | 2,700    | 2,700    | 3,800    | 2,900  |
| 135   |          |          |          |          |          |          |          |          |          |          |          |          | 2,200    | 3,300    | 2,400  |
| 140   |          |          |          |          |          |          |          |          |          |          |          |          | 1,800    | 2,900    | 2,000  |
| 145   |          |          |          |          |          |          |          |          |          |          |          |          |          |          | 1,600  |
| D   |          |          |          |          | 0°       |          |          |          | 10°      | 0°       | 12°      | 0°       | 15°      | 13°      | 26°    |
| Telescoping mode  | 1, 2     | 1        | 1        | 2        | 1        | 2        | 1        | 2        | 1        | 2        | 1        | 2        | 1        | 2        | 1, 2   |
| 2nd Boom  | 0        | 50       | 100      | 0        | 100      | 0        | 100      | 0        | 100      | 0        | 100      | 0        | 100      | 50       | 100    |
| 3rd Boom  | 0        | 0        | 0        | 33       | 16       | 50       | 33       | 67       | 50       | 83       | 67       | 100      | 83       | 100      | 100    |
| 4th Boom  | 0        | 0        | 0        | 33       | 16       | 50       | 33       | 67       | 50       | 83       | 67       | 100      | 83       | 100      | 100    |
| Top Boom  | 0        | 0        | 0        | 33       | 16       | 50       | 33       | 67       | 50       | 83       | 67       | 100      | 83       | 100      | 100    |

| COUNTERWEIGHT 24,700lbs (11.2 t)<br>ON OUTRIGGERS FULLY EXTENDED 23' 11-3/8" (7.3 m) SPREAD<br>360° ROTATION<br>SMART CW1 |            |            |            |            |            |            |            |            |            |            |            |            |            |            |      |       |       |       |       |       |   |   |   |   |   |   |   |   |
|---|------------|------------|------------|------------|------------|------------|------------|------------|------------|------------|------------|------------|------------|------------|------|-------|-------|-------|-------|-------|---|---|---|---|---|---|---|---|
| C \ A   | 42.0'      | 57.7'      | 73.3'      |            | 89.0'      |            | 104.7'     |            | 104.7'     |            | 120.3'     |            | 136.0'     |            |      |       |       |       |       |       |   |   |   |   |   |   |   |   |
|   | B (12.8 m) | B (17.6 m) | B (22.4 m) | B (22.4 m) | B (27.1 m) | B (27.1 m) | B (31.9 m) | B (31.9 m) | B (36.7 m) | B (36.7 m) | B (41.5 m) | B (41.5 m) | B (46.2 m) | B (46.2 m) |      |       |       |       |       |       |   |   |   |   |   |   |   |   |
| 0°  | 35.2       | 19,700     | 50.7       | 10,900     | 66.1       | 4,600      | 66.1       | 9,500      | 81.7       | 3,200      | 81.8       | 6,700      | 97.2       | 1,800      | 97.2 | 5,100 | 112.1 | 4,400 | 126.7 | 3,900 |   |   |   |   |   |   |   |   |
| Telescoping mode  | 1, 2       | 1          | 1          | 2          | 1          | 2          | 1          | 2          | 1          | 2          | 1          | 2          | 1          | 2          | 1    | 2     | 1     | 2     | 1     | 2     | 1 | 2 | 1 | 2 | 1 | 2 | 1 | 2 |

- A: Boom length in feet
- B: Load radius in feet
- C: Loaded boom angle (°)
- D: Minimum boom angle (°) for indicated length (no load)

NOTE: The lifting capacity data stored in the LOAD MOMENT INDICATOR (AML-E2) is based on the standard number of parts of line listed in the chart. Standard number of parts of line for each boom length should be according to the following table.

| Boom length in feet (meters) | 42.0' (12.8 m) | 42.0' to 73.3' (12.8 m to 22.4 m) | 73.3' to 167.3' (22.4 m to 51 m) | Single top jib |
|------------------------------|----------------|-----------------------------------|----------------------------------|----------------|
| Telescoping mode             | 1, 2           | 1                                 | 2                                | 1, 2           |
| Number of parts of line      | 16             | 8                                 | 4                                | 1              |

# GR-1000XLL-4 RATED LIFTING CAPACITIES (IN POUNDS)

|  |      | COUNTERWEIGHT 24,700lbs (11.2 t)<br>ON OUTRIGGERS FULLY EXTENDED 23' 11-3/8" (7.3 m) SPREAD<br>360° ROTATION<br>SMART CW2 |                   |         |                   |        |                   |        |                   |        |                    |        |                    |        |                    |        |                    |        |                  |  |
|---|------|---|-------------------|---------|-------------------|--------|-------------------|--------|-------------------|--------|--------------------|--------|--------------------|--------|--------------------|--------|--------------------|--------|------------------|--|
|   |      | A   | 42.0'<br>(12.8 m) |         | 57.7'<br>(17.6 m) |        | 73.3'<br>(22.4 m) |        | 89.0'<br>(27.1 m) |        | 104.7'<br>(31.9 m) |        | 120.3'<br>(36.7 m) |        | 136.0'<br>(41.5 m) |        | 151.7'<br>(46.2 m) |        | 167.3'<br>(51 m) |  |
| B   |      |   |                   |         |                   |        |                   |        |                   |        |                    |        |                    |        |                    |        |                    |        |                  |  |
|   |      | 8   |                   | 200,000 |                   | 99,600 |                   |        |                   |        |                    |        |                    |        |                    |        |                    |        |                  |  |
| 10  |      | 183,400   |                   | 99,600  | 74,800            | 33,800 |                   |        |                   |        |                    |        |                    |        |                    |        |                    |        |                  |  |
| 12  |      | 161,000   |                   | 99,600  | 74,800            | 33,800 |                   |        |                   |        |                    |        |                    |        |                    |        |                    |        |                  |  |
| 15  |      | 135,100   |                   | 99,600  | 74,800            | 33,800 | 39,900            | 29,700 |                   |        |                    |        |                    |        |                    |        |                    |        |                  |  |
| 20  |      | 103,900   |                   | 99,600  | 74,200            | 33,800 | 39,900            | 29,700 | 33,800            | 27,700 |                    |        |                    |        |                    |        |                    |        |                  |  |
| 25  |      | 80,100  |                   | 79,500  | 62,300            | 33,800 | 39,900            | 29,700 | 33,800            | 27,700 | 30,000             | 27,600 |                    |        |                    |        |                    |        |                  |  |
| 30  |      | 63,300  |                   | 62,500  | 53,400            | 33,800 | 39,900            | 29,700 | 33,800            | 27,700 | 30,000             | 27,600 | 28,300             | 27,500 |                    |        |                    |        |                  |  |
| 35  |      |   |                   | 49,400  | 46,500            | 33,800 | 39,300            | 29,700 | 33,800            | 27,700 | 30,000             | 27,400 | 28,300             | 23,900 | 26,400             | 26,400 | 23,600             | 20,700 |                  |  |
| 40  |      |   |                   | 38,400  | 37,400            | 33,800 | 34,600            | 29,700 | 31,200            | 27,700 | 28,800             | 25,000 | 27,100             | 21,500 | 25,400             | 22,000 | 22,000             | 20,700 |                  |  |
| 45  |      |   |                   | 30,700  | 29,800            | 33,800 | 30,700            | 29,700 | 27,600            | 26,300 | 25,500             | 23,000 | 24,000             | 19,500 | 22,900             | 20,500 | 20,500             | 20,100 |                  |  |
| 50  |      |   |                   | 25,100  | 24,100            | 30,100 | 26,200            | 29,700 | 24,700            | 23,900 | 22,800             | 21,200 | 21,400             | 17,800 | 20,400             | 19,100 | 19,000             |        |                  |  |
| 55  |      |   |                   |         | 19,800            | 25,600 | 21,800            | 26,300 | 22,300            | 22,000 | 20,500             | 19,800 | 19,200             | 16,300 | 18,300             | 17,600 | 17,600             |        |                  |  |
| 60  |      |   |                   |         | 16,400            | 21,900 | 18,300            | 22,700 | 19,300            | 20,300 | 18,500             | 18,200 | 17,400             | 15,000 | 16,500             | 16,200 | 15,800             |        |                  |  |
| 65  |      |   |                   |         | 13,600            | 19,000 | 15,400            | 19,700 | 16,500            | 18,800 | 16,800             | 16,900 | 15,700             | 14,000 | 14,900             | 15,100 | 14,300             |        |                  |  |
| 70  |      |   |                   |         |                   |        | 13,100            | 17,300 | 14,100            | 17,600 | 14,900             | 15,700 | 14,300             | 13,000 | 13,600             | 14,100 | 13,000             |        |                  |  |
| 75  |      |   |                   |         |                   |        | 11,100            | 15,300 | 12,100            | 15,700 | 12,900             | 14,700 | 13,100             | 12,100 | 12,400             | 13,200 | 11,800             |        |                  |  |
| 80  |      |   |                   |         |                   |        | 9,400             | 13,600 | 10,400            | 13,900 | 11,200             | 13,700 | 11,700             | 11,400 | 11,300             | 12,400 | 10,800             |        |                  |  |
| 85  |      |   |                   |         |                   |        |                   |        |                   | 9,000  | 12,400             | 9,700  | 12,700             | 10,200 | 10,700             | 10,400 | 11,700             | 9,900  |                  |  |
| 90  |      |   |                   |         |                   |        |                   |        |                   | 7,700  | 11,100             | 8,400  | 11,400             | 9,000  | 10,100             | 9,300  | 10,500             | 9,000  |                  |  |
| 95  |      |   |                   |         |                   |        |                   |        |                   | 6,600  | 10,000             | 7,300  | 10,200             | 7,800  | 9,500              | 8,200  | 9,300              | 8,300  |                  |  |
| 100   |      |   |                   |         |                   |        |                   |        |                   |        |                    | 6,300  | 9,200              | 6,800  | 9,000              | 7,200  | 8,400              | 7,500  |                  |  |
| 105   |      |   |                   |         |                   |        |                   |        |                   |        |                    | 5,500  | 8,300              | 5,900  | 8,500              | 6,300  | 7,500              | 6,600  |                  |  |
| 110   |      |   |                   |         |                   |        |                   |        |                   |        |                    | 4,700  | 7,600              | 5,100  | 7,700              | 5,500  | 6,600              | 5,800  |                  |  |
| 115   |      |   |                   |         |                   |        |                   |        |                   |        |                    |        |                    | 4,400  | 6,900              | 4,800  | 5,900              | 5,000  |                  |  |
| 120   |      |   |                   |         |                   |        |                   |        |                   |        |                    |        |                    | 3,800  | 6,300              | 4,100  | 5,300              | 4,400  |                  |  |
| 125   |      |   |                   |         |                   |        |                   |        |                   |        |                    |        |                    | 3,300  | 5,800              | 3,500  | 4,700              | 3,800  |                  |  |
| 130   |      |   |                   |         |                   |        |                   |        |                   |        |                    |        |                    |        |                    | 3,000  | 4,100              | 3,300  |                  |  |
| 135   |      |   |                   |         |                   |        |                   |        |                   |        |                    |        |                    |        |                    | 2,600  | 3,700              | 2,800  |                  |  |
| 140   |      |   |                   |         |                   |        |                   |        |                   |        |                    |        |                    |        |                    | 2,200  | 3,300              | 2,300  |                  |  |
| 145   |      |   |                   |         |                   |        |                   |        |                   |        |                    |        |                    |        |                    |        |                    | 1,900  |                  |  |
| 150   |      |   |                   |         |                   |        |                   |        |                   |        |                    |        |                    |        |                    |        |                    | 1,600  |                  |  |
| 155   |      |   |                   |         |                   |        |                   |        |                   |        |                    |        |                    |        |                    |        |                    | 1,300  |                  |  |
| D   | 0°   |   |                   |         |                   |        |                   |        |                   |        |                    |        |                    |        |                    |        |                    |        |                  |  |
| Telescoping mode  | 1, 2 | 1   | 1                 | 2       | 1                 | 2      | 1                 | 2      | 1                 | 2      | 1                  | 2      | 1                  | 2      | 1                  | 2      | 1                  | 2      | 1, 2             |  |
| 2nd Boom  | 0    | 50  | 100               | 0       | 100               | 0      | 100               | 0      | 100               | 0      | 100                | 0      | 100                | 0      | 100                | 0      | 100                | 50     | 100              |  |
| 3rd Boom  | 0    | 0   | 0                 | 33      | 16                | 50     | 33                | 67     | 50                | 83     | 67                 | 100    | 83                 | 100    | 83                 | 100    | 100                | 100    |                  |  |
| 4th Boom  | 0    | 0   | 0                 | 33      | 16                | 50     | 33                | 67     | 50                | 83     | 67                 | 100    | 83                 | 100    | 83                 | 100    | 100                |        |                  |  |
| Top Boom  | 0    | 0   | 0                 | 33      | 16                | 50     | 33                | 67     | 50                | 83     | 67                 | 100    | 83                 | 100    | 83                 | 100    | 100                |        |                  |  |

|  |    | COUNTERWEIGHT 24,700lbs (11.2 t)<br>ON OUTRIGGERS FULLY EXTENDED 23' 11-3/8" (7.3 m) SPREAD<br>360° ROTATION<br>SMART CW2 |                   |      |                   |      |                   |      |                   |      |                    |      |                    |      |                    |      |       |      |       |  |  |  |  |  |  |  |  |
|---|----|---|-------------------|------|-------------------|------|-------------------|------|-------------------|------|--------------------|------|--------------------|------|--------------------|------|-------|------|-------|--|--|--|--|--|--|--|--|
|   |    | A   | 42.0'<br>(12.8 m) |      | 57.7'<br>(17.6 m) |      | 73.3'<br>(22.4 m) |      | 89.0'<br>(27.1 m) |      | 104.7'<br>(31.9 m) |      | 120.3'<br>(36.7 m) |      | 136.0'<br>(41.5 m) |      |       |      |       |  |  |  |  |  |  |  |  |
| C   | 0° |   |                   |      |                   |      |                   |      |                   |      |                    |      |                    |      |                    |      |       |      |       |  |  |  |  |  |  |  |  |
|   |    |   |                   | 35.2 | 19,700            | 50.7 | 10,900            | 66.1 | 4,600             | 66.1 | 9,500              | 81.7 | 3,200              | 81.8 | 6,700              | 97.2 | 1,800 | 97.2 | 5,200 |  |  |  |  |  |  |  |  |
| Telescoping mode  |    | 1, 2  | 1                 | 1    | 2                 | 1    | 2                 | 1    | 2                 | 1    | 2                  | 1    | 2                  | 1    | 2                  | 1    | 2     |      |       |  |  |  |  |  |  |  |  |

A: Boom length in feet  
 B: Load radius in feet  
 C: Loaded boom angle (°)  
 D: Minimum boom angle (°) for indicated length (no load)

NOTE: The lifting capacity data stored in the LOAD MOMENT INDICATOR (AML-E2) is based on the standard number of parts of line listed in the chart. Standard number of parts of line for each boom length should be according to the following table.

| Boom length in feet (meters) | 42.0' (12.8 m) | 42.0' to 73.3' (12.8 m to 22.4 m) | 73.3' to 167.3' (22.4 m to 51 m) | Single top jib |
|------------------------------|----------------|-----------------------------------|----------------------------------|----------------|
| Telescoping mode             | 1, 2           | 1                                 | 2                                | 1, 2           |
| Number of parts of line      | 16             | 8                                 | 4                                | 1              |

# GR-1000XLL-4 RATED LIFTING CAPACITIES (IN POUNDS)

|                  |   | COUNTERWEIGHT 24,700lbs (11.2 t)<br>ON OUTRIGGERS FULLY EXTENDED 23' 11-3/8" (7.3 m) SPREAD |                   |                   |        |                   |        |                    |        |                    |        |                    |        |                    |        |                  |     |     |
|------------------|---|---|-------------------|-------------------|--------|-------------------|--------|--------------------|--------|--------------------|--------|--------------------|--------|--------------------|--------|------------------|-----|-----|
|                  |   | SMART CHART<br>SMART CW2  |                   |                   |        |                   |        |                    |        |                    |        |                    |        |                    |        |                  |     |     |
| B                | A | 42.0'<br>(12.8 m)   | 57.7'<br>(17.6 m) | 73.3'<br>(22.4 m) |        | 89.0'<br>(27.1 m) |        | 104.7'<br>(31.9 m) |        | 120.3'<br>(36.7 m) |        | 136.0'<br>(41.5 m) |        | 151.7'<br>(46.2 m) |        | 167.3'<br>(51 m) |     |     |
|                  | 8 |   | 200,000           | 99,600            |        |                   |        |                    |        |                    |        |                    |        |                    |        |                  |     |     |
| 10               |   | 183,400   | 99,600            | 74,800            | 33,800 |                   |        |                    |        |                    |        |                    |        |                    |        |                  |     |     |
| 12               |   | 161,000   | 99,600            | 74,800            | 33,800 |                   |        |                    |        |                    |        |                    |        |                    |        |                  |     |     |
| 15               |   | 135,100   | 99,600            | 74,800            | 33,800 | 39,900            | 29,700 |                    |        |                    |        |                    |        |                    |        |                  |     |     |
| 20               |   | 103,900   | 99,600            | 74,200            | 33,800 | 39,900            | 29,700 | 33,800             | 27,700 | 30,000             | 27,600 |                    |        |                    |        |                  |     |     |
| 25               |   | 80,100  | 79,500            | 62,300            | 33,800 | 39,900            | 29,700 | 33,800             | 27,700 | 30,000             | 27,600 | 28,300             | 27,500 |                    |        |                  |     |     |
| 30               |   | 63,300  | 62,500            | 53,400            | 33,800 | 39,900            | 29,700 | 33,800             | 27,700 | 30,000             | 27,600 | 28,300             | 26,100 | 26,400             | 24,100 |                  |     |     |
| 35               |   |   | 49,900            | 46,500            | 33,800 | 39,300            | 29,700 | 33,800             | 27,700 | 30,000             | 27,400 | 28,300             | 23,900 | 26,400             | 23,600 | 20,700           |     |     |
| 40               |   |   | 41,000            | 40,300            | 33,800 | 34,600            | 29,700 | 31,200             | 27,700 | 28,800             | 25,000 | 27,100             | 21,500 | 25,400             | 22,000 | 20,700           |     |     |
| 45               |   |   | 34,300            | 33,600            | 33,800 | 30,700            | 29,700 | 27,600             | 26,300 | 25,500             | 23,000 | 24,000             | 19,500 | 22,900             | 20,500 | 20,100           |     |     |
| 50               |   |   | 29,200            | 28,400            | 33,200 | 27,500            | 29,700 | 24,700             | 23,900 | 22,800             | 21,200 | 21,400             | 17,800 | 20,400             | 19,100 | 19,000           |     |     |
| 55               |   |   |                   | 24,200            | 29,000 | 24,800            | 29,600 | 22,300             | 22,000 | 20,500             | 19,800 | 19,200             | 16,300 | 18,300             | 17,600 | 17,600           |     |     |
| 60               |   |   |                   | 20,200            | 25,600 | 22,200            | 26,200 | 20,200             | 20,300 | 18,500             | 18,200 | 17,400             | 15,000 | 16,500             | 16,200 | 15,800           |     |     |
| 65               |   |   |                   | 17,100            | 22,600 | 18,900            | 23,300 | 18,300             | 18,800 | 16,800             | 16,900 | 15,700             | 14,000 | 14,900             | 15,100 | 14,300           |     |     |
| 70               |   |   |                   |                   |        | 16,100            | 20,500 | 16,800             | 17,600 | 15,400             | 15,700 | 14,300             | 13,000 | 13,600             | 14,100 | 13,000           |     |     |
| 75               |   |   |                   |                   |        | 13,900            | 18,200 | 15,000             | 16,400 | 14,100             | 14,700 | 13,100             | 12,100 | 12,400             | 13,200 | 11,800           |     |     |
| 80               |   |   |                   |                   |        | 11,900            | 16,200 | 13,000             | 15,500 | 12,900             | 13,700 | 12,000             | 11,400 | 11,300             | 12,400 | 10,800           |     |     |
| 85               |   |   |                   |                   |        |                   |        | 11,300             | 14,600 | 11,900             | 12,900 | 11,000             | 10,700 | 10,400             | 11,700 | 9,900            |     |     |
| 90               |   |   |                   |                   |        |                   |        | 9,900              | 13,400 | 10,600             | 12,200 | 10,100             | 10,100 | 9,500              | 11,000 | 9,000            |     |     |
| 95               |   |   |                   |                   |        |                   |        | 8,600              | 12,100 | 9,300              | 11,500 | 9,300              | 9,500  | 8,700              | 10,300 | 8,300            |     |     |
| 100              |   |   |                   |                   |        |                   |        |                    |        | 8,200              | 11,000 | 8,600              | 9,000  | 8,000              | 9,700  | 7,600            |     |     |
| 105              |   |   |                   |                   |        |                   |        |                    |        | 7,200              | 10,100 | 7,700              | 8,600  | 7,400              | 9,100  | 7,000            |     |     |
| 110              |   |   |                   |                   |        |                   |        |                    |        | 6,300              | 9,300  | 6,800              | 8,200  | 6,800              | 8,300  | 6,400            |     |     |
| 115              |   |   |                   |                   |        |                   |        |                    |        |                    |        | 6,000              | 7,800  | 6,300              | 7,500  | 5,900            |     |     |
| 120              |   |   |                   |                   |        |                   |        |                    |        |                    |        | 5,300              | 7,500  | 5,600              | 6,800  | 5,400            |     |     |
| 125              |   |   |                   |                   |        |                   |        |                    |        |                    |        | 4,700              | 7,200  | 5,000              | 6,100  | 5,000            |     |     |
| 130              |   |   |                   |                   |        |                   |        |                    |        |                    |        |                    |        | 4,400              | 5,500  | 4,600            |     |     |
| 135              |   |   |                   |                   |        |                   |        |                    |        |                    |        |                    |        | 3,800              | 5,000  | 4,100            |     |     |
| 140              |   |   |                   |                   |        |                   |        |                    |        |                    |        |                    |        | 3,400              | 4,500  | 3,600            |     |     |
| 145              |   |   |                   |                   |        |                   |        |                    |        |                    |        |                    |        |                    |        | 3,100            |     |     |
| 150              |   |   |                   |                   |        |                   |        |                    |        |                    |        |                    |        |                    |        | 2,700            |     |     |
| 155              |   |   |                   |                   |        |                   |        |                    |        |                    |        |                    |        |                    |        | 2,400            |     |     |
| D                |   | 0°  |                   |                   |        |                   |        |                    |        |                    |        | 9°                 | 0°     | 11°                | 0°     | 13°              | 12° | 16° |
| Telescoping mode |   | 1, 2  | 1                 | 1                 | 2      | 1                 | 2      | 1                  | 2      | 1                  | 2      | 1                  | 2      | 1                  | 2      | 1, 2             |     |     |
| 2nd Boom         |   | 0   | 50                | 100               | 0      | 100               | 0      | 100                | 0      | 100                | 0      | 100                | 0      | 100                | 50     | 100              |     |     |
| 3rd Boom         |   | 0   | 0                 | 0                 | 33     | 16                | 50     | 33                 | 67     | 50                 | 83     | 67                 | 100    | 83                 | 100    | 100              |     |     |
| 4th Boom         |   | 0   | 0                 | 0                 | 33     | 16                | 50     | 33                 | 67     | 50                 | 83     | 67                 | 100    | 83                 | 100    | 100              |     |     |
| Top Boom         |   | 0   | 0                 | 0                 | 33     | 16                | 50     | 33                 | 67     | 50                 | 83     | 67                 | 100    | 83                 | 100    | 100              |     |     |

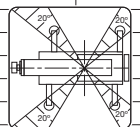

|                  |    | COUNTERWEIGHT 24,700lbs (11.2 t)<br>ON OUTRIGGERS FULLY EXTENDED 23' 11-3/8" (7.3 m) SPREAD |                   |                   |        |                   |       |                    |       |                    |       |                    |       |      |       |      |       |  |
|------------------|----|---|-------------------|-------------------|--------|-------------------|-------|--------------------|-------|--------------------|-------|--------------------|-------|------|-------|------|-------|--|
|                  |    | SMART CHART<br>SMART CW2  |                   |                   |        |                   |       |                    |       |                    |       |                    |       |      |       |      |       |  |
| C                | A  | 42.0'<br>(12.8 m)   | 57.7'<br>(17.6 m) | 73.3'<br>(22.4 m) |        | 89.0'<br>(27.1 m) |       | 104.7'<br>(31.9 m) |       | 120.3'<br>(36.7 m) |       | 136.0'<br>(41.5 m) |       |      |       |      |       |  |
|                  | 0° | 35.2  | 19,700            | 50.7              | 10,900 | 66.1              | 4,600 | 66.1               | 9,500 | 81.7               | 3,400 | 81.7               | 7,000 | 97.2 | 2,000 | 97.2 | 5,400 |  |
| Telescoping mode |    | 1, 2  | 1                 | 1                 | 2      | 1                 | 2     | 1                  | 2     | 1                  | 2     | 1                  | 2     | 1    | 2     |      |       |  |

A: Boom length in feet  
 B: Load radius in feet  
 C: Loaded boom angle (°)  
 D: Minimum boom angle (°) for indicated length (no load)

NOTE: The lifting capacity data stored in the LOAD MOMENT INDICATOR (AML-E2) is based on the standard number of parts of line listed in the chart. Standard number of parts of line for each boom length should be according to the following table.

| Boom length in feet (meters) | 42.0' (12.8 m) | 42.0' to 73.3' (12.8 m to 22.4 m) | 73.3' to 167.3' (22.4 m to 51 m) | Single top jib |
|------------------------------|----------------|-----------------------------------|----------------------------------|----------------|
| Telescoping mode             | 1, 2           | 1                                 | 2                                | 1, 2           |
| Number of parts of line      | 16             | 8                                 | 4                                | 1              |

# GR-1000XLL-4 RATED LIFTING CAPACITIES (IN POUNDS)

| COUNTERWEIGHT 24,700 lbs (11.2 t)<br>ON OUTRIGGERS FULLY EXTENDED 23' 11-3/8" (7.3 m) SPREAD<br>360° ROTATION<br>SMART CW1 |   |            |            |   |            |            |
|--|---|------------|------------|---|------------|------------|
| B  | 167.3' (51 m) Boom + 33.2' (10.1 m) JIB |            |            | 167.3' (51 m) Boom + 58.1' (17.7 m) JIB |            |            |
|  | 3.5° Offset                             | 25° Offset | 45° Offset | 3.5° Offset                             | 25° Offset | 45° Offset |
| 45   | 10,400                                  |            |            |   |            |            |
| 50   | 10,400                                  |            |            |   |            |            |
| 55   | 10,400                                  |            |            | 6,700                                   |            |            |
| 60   | 10,400                                  |            |            | 6,700                                   |            |            |
| 65   | 10,400                                  | 10,400     |            | 6,700                                   |            |            |
| 70   | 10,400                                  | 10,400     |            | 6,700                                   |            |            |
| 75   | 10,400                                  | 10,200     |            | 6,700                                   | 6,200      |            |
| 80   | 10,400                                  | 9,500      |            | 6,700                                   | 6,100      |            |
| 85   | 9,800                                   | 9,000      |            | 6,700                                   | 5,900      |            |
| 90   | 9,200                                   | 8,500      |            | 6,700                                   | 5,800      | 4,800      |
| 95   | 8,500                                   | 8,000      |            | 6,700                                   | 5,600      | 4,700      |
| 100  | 7,500                                   | 7,600      |            | 6,700                                   | 5,500      | 4,600      |
| 105  | 6,700                                   | 7,200      |            | 6,600                                   | 5,400      | 4,500      |
| 110  | 5,800                                   | 6,700      |            | 6,200                                   | 5,300      | 4,400      |
| 115  | 5,100                                   | 5,900      |            | 5,400                                   | 5,200      | 4,300      |
| 120  | 4,500                                   | 5,200      |            | 4,800                                   | 5,000      | 4,200      |
| 125  | 3,900                                   | 4,500      |            | 4,200                                   | 4,900      | 4,200      |
| 130  | 3,300                                   | 3,900      |            | 3,600                                   | 4,600      | 4,100      |
| 135  | 2,800                                   | 3,400      |            | 3,100                                   | 4,200      | 4,000      |
| 140  | 2,400                                   | 2,800      |            | 2,700                                   | 3,700      | 4,000      |
| 145  | 1,900                                   | 2,400      |            | 2,200                                   | 3,200      | 3,800      |
| 150  | 1,500                                   | 1,900      |            | 1,900                                   | 2,700      | 3,200      |
| 155  |   | 1,500      |            | 1,500                                   | 2,300      | 2,800      |
| 160  |   |            |            |   | 1,900      | 2,300      |
| 165  |   |            |            |   | 1,500      | 1,900      |
| 170  |   |            |            |   |            | 1,500      |
| Telescoping mode   | 1, 2                                    | 1, 2       | 1, 2       | 1, 2                                    | 1, 2       | 1, 2       |

| COUNTERWEIGHT 24,700 lbs (11.2 t)<br>ON OUTRIGGERS FULLY EXTENDED 23' 11-3/8" (7.3 m) SPREAD<br>360° ROTATION<br>SMART CW1 |   |            |            |   |            |            |
|--|---|------------|------------|---|------------|------------|
| B  | 151.7' (46.2 m) Boom + 33.2' (10.1 m) JIB |            |            | 151.7' (46.2 m) Boom + 58.1' (17.7 m) JIB |            |            |
|  | 3.5° Offset                               | 25° Offset | 45° Offset | 3.5° Offset                               | 25° Offset | 45° Offset |
| 40   | 12,500                                    | 11,500     |            |   |            |            |
| 45   | 12,500                                    | 11,500     |            |   |            |            |
| 50   | 12,500                                    | 11,500     |            |   |            |            |
| 55   | 12,500                                    | 11,500     | 12,500     | 11,500                                    |            |            |
| 60   | 12,500                                    | 11,500     | 12,500     | 11,500                                    | 10,000     | 10,000     |
| 65   | 12,500                                    | 11,500     | 12,100     | 11,100                                    | 9,800      | 9,700      |
| 70   | 12,500                                    | 11,500     | 11,700     | 10,300                                    | 9,600      | 9,500      |
| 75   | 12,500                                    | 10,900     | 11,400     | 9,700                                     | 9,400      | 9,200      |
| 80   | 11,700                                    | 10,300     | 11,000     | 9,100                                     | 9,200      | 8,600      |
| 85   | 10,700                                    | 9,800      | 10,700     | 8,500                                     | 9,100      | 8,200      |
| 90   | 9,800                                     | 8,600      | 10,100     | 8,000                                     | 8,900      | 7,700      |
| 95   | 8,700                                     | 8,000      | 9,300      | 7,600                                     | 8,800      | 7,300      |
| 100  | 7,700                                     | 7,600      | 8,600      | 7,100                                     | 8,700      | 6,900      |
| 105  | 6,800                                     | 7,100      | 7,600      | 6,800                                     | 8,000      | 6,600      |
| 110  | 6,000                                     | 6,700      | 6,700      | 6,400                                     | 7,200      | 6,200      |
| 115  | 5,200                                     | 6,200      | 6,000      | 6,100                                     | 6,300      | 6,000      |
| 120  | 4,600                                     | 5,600      | 5,200      | 5,800                                     | 5,600      | 5,700      |
| 125  | 4,000                                     | 5,000      | 4,600      | 5,400                                     | 4,900      | 5,400      |
| 130  | 3,400                                     | 4,400      | 3,900      | 4,900                                     | 4,200      | 5,000      |
| 135  | 2,900                                     | 3,900      | 3,400      | 4,300                                     | 3,600      | 4,500      |
| 140  | 2,400                                     | 3,400      | 2,900      | 3,800                                     |            |            |
| 145  | 2,000                                     | 3,000      | 2,400      | 3,300                                     |            |            |
| 150  | 1,600                                     | 2,600      | 2,000      | 2,900                                     |            |            |
| 155  | 1,300                                     | 2,200      | 1,500      | 2,400                                     |            |            |
| 160  | 900                                       | 1,900      | 1,100      | 2,100                                     |            |            |
| 165  |   | 1,500      |            | 1,700                                     |            |            |
| 170  |   | 1,300      |            |   |            |            |
| 175  |   | 1,000      |            |   |            |            |
| 180  |   |            |            |   |            |            |
| 185  |   |            |            |   |            |            |
| Telescoping mode   | 1   | 2          | 1          | 2   | 1          | 2          |

| COUNTERWEIGHT 24,700 lbs (11.2 t)<br>ON OUTRIGGERS FULLY EXTENDED 23' 11-3/8" (7.3 m) SPREAD<br>360° ROTATION<br>SMART CW1 |   |            |            |   |            |            |
|--|---|------------|------------|---|------------|------------|
| B  | 120.3' (36.7 m) Boom + 33.2' (10.1 m) JIB |            |            | 120.3' (36.7 m) Boom + 58.1' (17.7 m) JIB |            |            |
|  | 3.5° Offset                               | 25° Offset | 45° Offset | 3.5° Offset                               | 25° Offset | 45° Offset |
| 30   | 14,600                                    | 14,600     |            |   |            |            |
| 35   | 14,600                                    | 14,600     |            |   |            |            |
| 40   | 14,600                                    | 14,600     | 14,400     |   |            |            |
| 45   | 14,600                                    | 14,600     | 13,800     | 13,600                                    |            |            |
| 50   | 14,600                                    | 14,600     | 13,200     | 13,000                                    | 10,400     | 10,400     |
| 55   | 14,600                                    | 14,600     | 12,700     | 12,500                                    | 10,200     | 10,100     |
| 60   | 14,600                                    | 14,400     | 12,200     | 12,000                                    | 9,900      | 9,800      |
| 65   | 14,600                                    | 13,400     | 11,800     | 11,600                                    | 9,700      | 9,600      |
| 70   | 14,600                                    | 12,600     | 11,400     | 11,200                                    | 9,500      | 9,400      |
| 75   | 13,900                                    | 12,400     | 11,000     | 10,800                                    | 9,300      | 9,200      |
| 80   | 12,400                                    | 11,700     | 10,700     | 10,500                                    | 9,200      | 9,100      |
| 85   | 10,900                                    | 11,000     | 10,400     | 10,200                                    | 9,000      | 8,900      |
| 90   | 9,600                                     | 10,300     | 10,100     | 9,900                                     | 8,900      | 8,800      |
| 95   | 8,500                                     | 9,800      | 9,300      | 9,700                                     | 8,800      | 8,700      |
| 100  | 7,500                                     | 9,300      | 8,200      | 9,200                                     | 8,600      | 8,600      |
| 105  | 6,600                                     | 8,800      | 7,200      | 8,700                                     | 7,600      | 8,500      |
| 110  | 5,800                                     | 7,900      | 6,300      | 8,300                                     | 6,600      | 8,300      |
| 115  | 5,000                                     | 7,200      | 5,500      | 7,600                                     | 5,800      | 7,800      |
| 120  | 4,400                                     | 6,500      | 4,800      | 6,900                                     |            |            |
| 125  | 3,700                                     | 5,900      | 4,100      | 6,200                                     |            |            |
| 130  | 3,200                                     | 5,400      | 3,500      | 5,600                                     |            |            |
| 135  | 2,700                                     | 4,900      | 2,900      | 5,000                                     |            |            |
| 140  | 2,200                                     | 4,400      |            |   |            |            |
| 145  | 1,800                                     | 4,000      |            |   |            |            |
| 150  |   |            |            |   |            |            |
| 155  |   |            |            |   |            |            |
| 160  |   |            |            |   |            |            |
| 165  |   |            |            |   |            |            |
| 170  |   |            |            |   |            |            |
| Telescoping mode   | 1   | 2          | 1          | 2   | 1          | 2          |

B: Load radius in feet

# GR-1000XLL-4 RATED LIFTING CAPACITIES (IN POUNDS)

| COUNTERWEIGHT 24,700 lbs (11.2 t)<br>ON OUTRIGGERS FULLY EXTENDED 23' 11-3/8" (7.3 m) SPREAD<br>360° ROTATION<br>SMART CW2 |   |  |            |  |            |       |   |  |            |  |            |      |
|--|---|--|------------|--|------------|-------|---|--|------------|--|------------|------|
| B  | 167.3' (51 m) Boom + 33.2' (10.1 m) JIB |  |            |  |            |       | 167.3' (51 m) Boom + 58.1' (17.7 m) JIB |  |            |  |            |      |
|  | 3.5° Offset                             |  | 25° Offset |  | 45° Offset |       | 3.5° Offset                             |  | 25° Offset |  | 45° Offset |      |
| 45   | 10,400                                  |  |            |  |            |       |   |  |            |  |            |      |
| 50   | 10,400                                  |  |            |  |            |       |   |  |            |  |            |      |
| 55   | 10,400                                  |  |            |  |            |       | 6,700                                   |  |            |  |            |      |
| 60   | 10,400                                  |  |            |  |            |       | 6,700                                   |  |            |  |            |      |
| 65   | 10,400                                  |  | 10,400     |  |            |       | 6,700                                   |  |            |  |            |      |
| 70   | 10,400                                  |  | 10,400     |  |            | 9,800 | 6,700                                   |  |            |  |            |      |
| 75   | 10,400                                  |  | 10,400     |  |            | 9,600 | 6,700                                   |  |            |  |            |      |
| 80   | 10,400                                  |  | 10,200     |  |            | 9,400 | 6,700                                   |  | 6,200      |  |            |      |
| 85   | 9,800                                   |  | 9,500      |  |            | 9,000 | 6,700                                   |  | 6,100      |  |            |      |
| 90   | 9,200                                   |  | 9,000      |  |            | 8,500 | 6,700                                   |  | 5,900      |  |            |      |
| 95   | 8,700                                   |  | 8,500      |  |            | 8,100 | 6,700                                   |  | 5,800      |  | 4,800      |      |
| 100  | 7,900                                   |  | 7,600      |  |            | 7,300 | 6,700                                   |  | 5,600      |  | 4,700      |      |
| 105  | 7,200                                   |  | 6,800      |  |            | 6,900 | 6,600                                   |  | 5,500      |  | 4,600      |      |
| 110  | 6,300                                   |  | 6,300      |  |            | 6,600 | 6,600                                   |  | 5,400      |  | 4,500      |      |
| 115  | 5,600                                   |  | 6,300      |  |            | 6,300 | 6,200                                   |  | 5,300      |  | 4,400      |      |
| 120  | 4,900                                   |  | 5,600      |  |            | 6,000 | 5,800                                   |  | 5,200      |  | 4,300      |      |
| 125  | 4,300                                   |  | 4,900      |  |            | 5,300 | 5,200                                   |  | 5,000      |  | 4,200      |      |
| 130  | 3,700                                   |  | 4,300      |  |            | 4,700 | 4,600                                   |  | 4,900      |  | 4,200      |      |
| 135  | 3,200                                   |  | 3,800      |  |            | 4,100 | 4,100                                   |  | 4,600      |  | 4,100      |      |
| 140  | 2,800                                   |  | 3,200      |  |            | 3,500 | 4,100                                   |  | 4,400      |  | 4,000      |      |
| 145  | 2,300                                   |  | 2,800      |  |            | 3,000 | 3,100                                   |  | 4,100      |  | 4,000      |      |
| 150  | 1,900                                   |  | 2,300      |  |            | 2,500 | 2,600                                   |  | 3,500      |  | 3,900      |      |
| 155  | 1,500                                   |  | 1,900      |  |            |       | 2,200                                   |  | 3,100      |  | 3,600      |      |
| 160  | 1,200                                   |  | 1,500      |  |            |       | 1,900                                   |  | 2,600      |  | 3,100      |      |
| 165  |   |  | 1,100      |  |            |       | 1,500                                   |  | 2,200      |  | 2,700      |      |
| 170  |   |  |            |  |            |       |   |  | 1,900      |  | 2,200      |      |
| 175  |   |  |            |  |            |       |   |  | 1,500      |  | 1,800      |      |
| 175  |   |  |            |  |            |       |   |  |            |  | 1,400      |      |
| Telescoping mode   | 1, 2                                    |  | 1, 2       |  |            | 1, 2  | 1, 2                                    |  | 1, 2       |  |            | 1, 2 |

| COUNTERWEIGHT 24,700 lbs (11.2 t)<br>ON OUTRIGGERS FULLY EXTENDED 23' 11-3/8" (7.3 m) SPREAD<br>360° ROTATION<br>SMART CW2 |   |        |            |        |            |        |   |       |            |       |            |       |
|--|---|--------|------------|--------|------------|--------|---|-------|------------|-------|------------|-------|
| B  | 151.7' (46.2 m) Boom + 33.2' (10.1 m) JIB |        |            |        |            |        | 151.7' (46.2 m) Boom + 58.1' (17.7 m) JIB |       |            |       |            |       |
|  | 3.5° Offset                               |        | 25° Offset |        | 45° Offset |        | 3.5° Offset                               |       | 25° Offset |       | 45° Offset |       |
| 40   | 12,500                                    | 11,500 |            |        |            |        |   |       |            |       |            |       |
| 45   | 12,500                                    | 11,500 |            |        |            |        |   |       |            |       |            |       |
| 50   | 12,500                                    | 11,500 |            |        |            |        | 7,600                                     | 7,200 |            |       |            |       |
| 55   | 12,500                                    | 11,500 | 12,500     | 11,500 |            |        | 7,600                                     | 7,200 |            |       |            |       |
| 60   | 12,500                                    | 11,500 | 12,500     | 11,500 | 10,000     | 10,000 | 7,600                                     | 7,200 |            |       |            |       |
| 65   | 12,500                                    | 11,500 | 12,100     | 11,100 | 9,800      | 9,700  | 7,600                                     | 7,200 |            |       |            |       |
| 70   | 12,500                                    | 11,500 | 11,700     | 10,300 | 9,600      | 9,500  | 7,600                                     | 7,200 | 6,500      | 6,500 |            |       |
| 75   | 12,500                                    | 10,900 | 11,400     | 9,700  | 9,400      | 9,200  | 7,600                                     | 7,200 | 6,300      | 6,300 |            |       |
| 80   | 11,700                                    | 10,300 | 11,000     | 9,100  | 9,200      | 8,600  | 7,600                                     | 7,200 | 6,200      | 6,100 | 5,000      |       |
| 85   | 10,700                                    | 9,800  | 10,700     | 8,500  | 9,100      | 8,200  | 7,600                                     | 7,200 | 6,000      | 5,900 | 4,900      | 4,900 |
| 90   | 9,800                                     | 8,600  | 10,100     | 8,000  | 8,900      | 7,700  | 7,600                                     | 7,200 | 5,900      | 5,800 | 4,800      | 4,800 |
| 95   | 9,000                                     | 8,000  | 9,300      | 7,600  | 8,800      | 7,300  | 7,300                                     | 7,000 | 5,700      | 5,600 | 4,700      | 4,700 |
| 100  | 8,200                                     | 7,600  | 8,600      | 7,100  | 8,700      | 6,900  | 7,100                                     | 6,500 | 5,600      | 5,500 | 4,600      | 4,500 |
| 105  | 7,300                                     | 7,100  | 7,900      | 6,800  | 8,000      | 6,600  | 6,900                                     | 6,100 | 5,400      | 5,400 | 4,500      | 4,500 |
| 110  | 6,500                                     | 6,700  | 7,200      | 6,400  | 7,400      | 6,200  | 6,700                                     | 5,800 | 5,300      | 5,300 | 4,400      | 4,400 |
| 115  | 5,700                                     | 6,300  | 6,400      | 6,100  | 6,800      | 6,000  | 6,200                                     | 5,400 | 5,200      | 5,100 | 4,300      | 4,300 |
| 120  | 5,000                                     | 6,000  | 5,600      | 5,800  | 6,000      | 5,700  | 5,500                                     | 5,100 | 5,000      | 4,800 | 4,200      | 4,200 |
| 125  | 4,400                                     | 5,400  | 5,000      | 5,500  | 5,200      | 5,400  | 4,900                                     | 4,800 | 4,900      | 4,600 | 4,100      | 4,100 |
| 130  | 3,800                                     | 4,800  | 4,400      | 5,200  | 4,600      | 5,200  | 4,300                                     | 4,600 | 4,700      | 4,300 | 4,100      | 4,100 |
| 135  | 3,300                                     | 4,300  | 3,800      | 4,700  | 4,000      | 4,800  | 3,800                                     | 4,300 | 4,600      | 4,100 | 4,000      | 4,000 |
| 140  | 2,800                                     | 3,800  | 3,300      | 4,100  |            |        | 3,300                                     | 4,100 | 4,200      | 3,900 | 4,000      | 3,800 |
| 145  | 2,400                                     | 3,300  | 2,800      | 3,600  |            |        | 2,800                                     | 3,700 | 3,700      | 3,700 | 3,900      | 3,700 |
| 150  | 2,000                                     | 2,900  | 2,300      | 3,200  |            |        | 2,400                                     | 3,400 | 3,200      | 3,500 | 3,700      | 3,500 |
| 155  | 1,600                                     | 2,500  | 1,900      | 2,800  |            |        | 2,100                                     | 3,000 | 2,800      | 3,400 | 3,200      | 3,300 |
| 160  | 1,300                                     | 2,200  | 1,500      | 2,400  |            |        | 1,700                                     | 2,600 | 2,300      | 3,200 | 2,700      | 3,200 |
| 165  |   | 1,900  | 1,100      | 2,000  |            |        | 1,400                                     | 2,300 | 1,900      | 2,800 |            |       |
| 170  |   | 1,500  |            |        |            |        | 1,100                                     | 2,000 | 1,600      | 2,400 |            |       |
| 175  |   | 1,300  |            |        |            |        |   | 1,700 | 1,200      | 2,100 |            |       |
| 180  |   |        |            |        |            |        |   | 1,400 |            | 1,700 |            |       |
| 185  |   |        |            |        |            |        |   | 1,200 |            | 1,400 |            |       |
| Telescoping mode   | 1   | 2      | 1          | 2      | 1          | 2      | 1   | 2     | 1          | 2     | 1          | 2     |

| COUNTERWEIGHT 24,700 lbs (11.2 t)<br>ON OUTRIGGERS FULLY EXTENDED 23' 11-3/8" (7.3 m) SPREAD<br>360° ROTATION<br>SMART CW2 |   |        |            |        |            |        |   |       |            |       |            |       |
|--|---|--------|------------|--------|------------|--------|---|-------|------------|-------|------------|-------|
| B  | 120.3' (36.7 m) Boom + 33.2' (10.1 m) JIB |        |            |        |            |        | 120.3' (36.7 m) Boom + 58.1' (17.7 m) JIB |       |            |       |            |       |
|  | 3.5° Offset                               |        | 25° Offset |        | 45° Offset |        | 3.5° Offset                               |       | 25° Offset |       | 45° Offset |       |
| 30   | 14,600                                    | 14,600 |            |        |            |        |   |       |            |       |            |       |
| 35   | 14,600                                    | 14,600 |            |        |            |        |   |       |            |       |            |       |
| 40   | 14,600                                    | 14,600 | 14,400     |        |            |        | 9,900                                     | 8,700 |            |       |            |       |
| 45   | 14,600                                    | 14,600 | 13,800     | 13,600 |            |        | 9,900                                     | 8,700 |            |       |            |       |
| 50   | 14,600                                    | 14,600 | 13,200     | 13,000 | 10,400     | 10,400 | 9,900                                     | 8,700 |            |       |            |       |
| 55   | 14,600                                    | 14,600 | 12,700     | 12,500 | 10,200     | 10,100 | 9,900                                     | 8,700 |            |       |            |       |
| 60   | 14,600                                    | 14,400 | 12,200     | 12,000 | 9,900      | 9,800  | 9,900                                     | 8,700 |            |       |            |       |
| 65   | 14,600                                    | 13,400 | 11,800     | 11,600 | 9,700      | 9,600  | 9,600                                     | 8,700 | 7,200      | 7,000 |            |       |
| 70   | 14,600                                    | 12,600 | 11,400     | 11,200 | 9,500      | 9,400  | 9,100                                     | 8,700 | 6,700      | 6,500 | 5,300      | 5,300 |
| 75   | 13,900                                    | 12,400 | 11,000     | 10,800 | 9,300      | 9,200  | 8,700                                     | 8,400 | 6,500      | 6,300 | 5,200      | 5,100 |
| 80   | 12,800                                    | 11,700 | 10,700     | 10,500 | 9,200      | 9,100  | 8,300                                     | 8,000 | 6,300      | 6,200 | 5,000      | 5,000 |
| 85   | 11,500                                    | 11,000 | 10,400     | 10,200 | 9,000      | 8,900  | 8,000                                     | 7,700 | 6,100      | 6,000 | 4,900      | 4,800 |
| 90   | 10,200                                    | 10,300 | 10,100     | 9,900  | 8,900      | 8,800  | 7,700                                     | 7,400 | 5,800      | 5,800 | 4,700      | 4,700 |
| 95   | 9,000                                     | 9,800  | 9,800      | 9,700  | 8,800      | 8,700  | 7,400                                     | 7,100 | 5,600      | 5,500 | 4,600      | 4,600 |
| 100  | 8,000                                     | 9,300  | 8,700      | 9,200  | 8,700      | 8,600  | 7,100                                     | 6,900 | 5,400      | 5,300 | 4,500      | 4,500 |
| 105  | 7,000                                     | 8,800  | 7,700      | 8,700  | 8,000      | 8,500  | 6,800                                     | 6,600 | 5,200      | 5,200 | 4,400      | 4,400 |
| 110  | 6,200                                     | 8,300  | 6,800      | 8,300  | 7,100      | 8,300  | 6,600                                     | 6,400 | 5,100      | 5,000 | 4,300      | 4,300 |
| 115  | 5,400                                     | 7,600  | 6,000      | 7,900  | 6,200      | 7,900  | 6,400                                     | 6,200 | 4,900      | 4,900 | 4,300      | 4,200 |
| 120  | 4,800                                     | 6,900  | 5,200      | 7,300  |            |        | 5,700                                     | 6,000 | 4,800      | 4,700 | 4,200      | 4,100 |
| 125  | 4,100                                     | 6,300  | 4,500      | 6,600  |            |        | 5,100                                     | 5,800 | 4,600      | 4,600 | 4,100      | 4,100 |
| 130  | 3,600                                     | 5,800  | 3,900      | 6,000  |            |        | 4,500                                     | 5,600 | 4,500      | 4,500 | 4,100      | 4,000 |
| 135  | 3,100                                     | 5,200  | 3,300      | 5,400  |            |        | 4,000                                     | 5,300 | 4,400      | 4,300 | 4,000      | 4,000 |
| 140  | 2,600                                     | 4,700  |            |        |            |        | 3,500                                     | 5,100 | 4,100      | 4,300 | 4,000      | 4,000 |
| 145  | 2,200                                     | 4,300  |            |        |            |        | 3,000                                     | 4,900 | 3,600      | 4,200 |            |       |
| 150  |   |        |            |        |            |        | 2,600                                     | 4,400 | 3,100      | 4,100 |            |       |
| 155  |   |        |            |        |            |        | 2,200                                     | 4,100 | 2,600      | 4,000 |            |       |
| 160  |   |        |            |        |            |        | 1,900                                     | 3,700 | 2,200      | 3,900 |            |       |
| 165  |   |        |            |        |            |        | 1,500                                     | 3,400 |            |       |            |       |
| 170  |   |        |            |        |            |        | 1,200                                     | 3,100 |            |       |            |       |
| Telescoping mode   | 1   | 2      | 1          | 2      | 1          | 2      | 1   | 2     | 1          | 2     | 1          | 2     |

B: Load radius in feet

# GR-1000XLL-4 RATED LIFTING CAPACITIES (IN POUNDS)

COUNTERWEIGHT 24,700 lbs (11.2 t)  
ON OUTRIGGERS FULLY EXTENDED 23' 11-3/8" (7.3 m) SPREAD

SMART CHART  
SMART CW2

| B                | 167.3' (51 m) Boom + 33.2' (10.1 m) JIB |            |            | B                | 167.3' (51 m) Boom + 58.1' (17.7 m) JIB |            |            |
|------------------|---|------------|------------|------------------|---|------------|------------|
|                  | 3.5° Offset                             | 25° Offset | 45° Offset |                  | 3.5° Offset                             | 25° Offset | 45° Offset |
| 45               | 10,400                                  |            |            |                  |   |            |            |
| 50               | 10,400                                  |            |            |                  |   |            |            |
| 55               | 10,400                                  |            |            | 6,700            |   |            |            |
| 60               | 10,400                                  |            |            | 6,700            |   |            |            |
| 65               | 10,400                                  | 10,400     |            | 6,700            |   |            |            |
| 70               | 10,400                                  | 10,400     | 9,800      | 6,700            |   |            |            |
| 75               | 10,400                                  | 10,400     | 9,600      | 6,700            |   |            |            |
| 80               | 10,400                                  | 10,200     | 9,400      | 6,700            |   | 6,200      |            |
| 85               | 9,800                                   | 9,500      | 9,000      | 6,700            |   | 6,100      |            |
| 90               | 9,200                                   | 9,000      | 8,500      | 6,700            |   | 5,900      |            |
| 95               | 8,700                                   | 8,500      | 8,100      | 6,700            |   | 5,800      | 4,800      |
| 100              | 7,900                                   | 8,000      | 7,700      | 6,700            |   | 5,600      | 4,700      |
| 105              | 7,300                                   | 7,600      | 7,300      | 6,700            |   | 5,500      | 4,600      |
| 110              | 6,700                                   | 7,200      | 6,900      | 6,600            |   | 5,400      | 4,500      |
| 115              | 6,100                                   | 6,800      | 6,600      | 6,200            |   | 5,300      | 4,400      |
| 120              | 5,600                                   | 6,500      | 6,300      | 5,800            |   | 5,200      | 4,300      |
| 125              | 5,100                                   | 6,000      | 6,000      | 5,500            |   | 5,000      | 4,200      |
| 130              | 4,700                                   | 5,400      | 5,600      | 5,200            |   | 4,900      | 4,200      |
| 135              | 4,300                                   | 5,000      | 5,100      | 4,900            |   | 4,600      | 4,100      |
| 140              | 3,900                                   | 4,600      | 4,700      | 4,500            |   | 4,400      | 4,000      |
| 145              | 3,500                                   | 4,200      | 4,300      | 4,100            |   | 4,200      | 4,000      |
| 150              | 3,100                                   | 3,800      | 3,900      | 3,700            |   | 4,000      | 3,900      |
| 155              | 2,700                                   | 3,400      | 3,500      | 3,400            |   | 3,800      | 3,700      |
| 160              | 2,300                                   | 3,000      | 3,100      | 3,000            |   | 3,500      | 3,500      |
| 165              | 2,000                                   | 2,700      | 2,800      | 2,600            |   | 3,200      | 3,400      |
| 170              | 1,700                                   | 2,400      | 2,500      | 2,300            |   | 2,900      | 3,100      |
| 175              | 1,300                                   | 2,100      | 2,200      | 2,000            |   | 2,600      | 2,800      |
| 180              | 1,100                                   | 1,900      | 2,000      | 1,800            |   | 2,200      | 2,500      |
| 185              |   | 1,700      | 1,800      | 1,600            |   | 1,900      |            |
| 190              |   | 1,500      | 1,600      | 1,400            |   | 1,700      |            |
| Telescoping mode | 1, 2                                    | 1, 2       | 1, 2       | Telescoping mode | 1, 2                                    | 1, 2       | 1, 2       |

COUNTERWEIGHT 24,700 lbs (11.2 t)  
ON OUTRIGGERS FULLY EXTENDED 23' 11-3/8" (7.3 m) SPREAD

SMART CHART  
SMART CW2

| B                | 151.7' (46.2 m) Boom + 33.2' (10.1 m) JIB |            |            |            | B                | 151.7' (46.2 m) Boom + 58.1' (17.7 m) JIB |            |            |            |
|------------------|---|------------|------------|------------|------------------|---|------------|------------|------------|
|                  | 3.5° Offset                               | 25° Offset | 45° Offset | 45° Offset |                  | 3.5° Offset                               | 25° Offset | 45° Offset | 45° Offset |
| 40               | 12,500                                    |            |            |            |                  |   |            |            |            |
| 45               | 12,500                                    |            |            |            |                  |   |            |            |            |
| 50               | 12,500                                    |            |            |            |                  |   |            |            |            |
| 55               | 12,500                                    |            |            |            |                  |   |            |            |            |
| 60               | 12,500                                    |            |            |            |                  |   |            |            |            |
| 65               | 12,500                                    |            |            |            |                  |   |            |            |            |
| 70               | 12,500                                    |            |            |            |                  |   |            |            |            |
| 75               | 12,500                                    |            |            |            |                  |   |            |            |            |
| 80               | 11,700                                    |            |            |            |                  |   |            |            |            |
| 85               | 10,700                                    |            |            |            |                  |   |            |            |            |
| 90               | 9,800                                     |            |            |            |                  |   |            |            |            |
| 95               | 9,000                                     |            |            |            |                  |   |            |            |            |
| 100              | 8,200                                     |            |            |            |                  |   |            |            |            |
| 105              | 7,600                                     |            |            |            |                  |   |            |            |            |
| 110              | 7,000                                     |            |            |            |                  |   |            |            |            |
| 115              | 6,400                                     |            |            |            |                  |   |            |            |            |
| 120              | 5,900                                     |            |            |            |                  |   |            |            |            |
| 125              | 5,400                                     |            |            |            |                  |   |            |            |            |
| 130              | 5,000                                     |            |            |            |                  |   |            |            |            |
| 135              | 4,600                                     |            |            |            |                  |   |            |            |            |
| 140              | 4,100                                     |            |            |            |                  |   |            |            |            |
| 145              | 3,600                                     |            |            |            |                  |   |            |            |            |
| 150              | 3,200                                     |            |            |            |                  |   |            |            |            |
| 155              | 2,700                                     |            |            |            |                  |   |            |            |            |
| 160              | 2,300                                     |            |            |            |                  |   |            |            |            |
| 165              | 2,000                                     |            |            |            |                  |   |            |            |            |
| 170              | 1,600                                     |            |            |            |                  |   |            |            |            |
| 175              | 1,300                                     |            |            |            |                  |   |            |            |            |
| 180              |   |            |            |            |                  |   |            |            |            |
| 185              |   |            |            |            |                  |   |            |            |            |
| 190              |   |            |            |            |                  |   |            |            |            |
| Telescoping mode | 1   | 2          | 1          | 2          | Telescoping mode | 1   | 2          | 1          | 2          |

COUNTERWEIGHT 24,700 lbs (11.2 t)  
ON OUTRIGGERS FULLY EXTENDED 23' 11-3/8" (7.3 m) SPREAD

SMART CHART  
SMART CW2

| B                | 120.3' (36.7 m) Boom + 33.2' (10.1 m) JIB |            |            |            | B                | 120.3' (36.7 m) Boom + 58.1' (17.7 m) JIB |            |            |            |
|------------------|---|------------|------------|------------|------------------|---|------------|------------|------------|
|                  | 3.5° Offset                               | 25° Offset | 45° Offset | 45° Offset |                  | 3.5° Offset                               | 25° Offset | 45° Offset | 45° Offset |
| 30               | 14,600                                    |            |            |            |                  |   |            |            |            |
| 35               | 14,600                                    |            |            |            |                  |   |            |            |            |
| 40               | 14,600                                    |            |            |            |                  |   |            |            |            |
| 45               | 14,600                                    |            |            |            |                  |   |            |            |            |
| 50               | 14,600                                    |            |            |            |                  |   |            |            |            |
| 55               | 14,600                                    |            |            |            |                  |   |            |            |            |
| 60               | 14,600                                    |            |            |            |                  |   |            |            |            |
| 65               | 14,600                                    |            |            |            |                  |   |            |            |            |
| 70               | 14,600                                    |            |            |            |                  |   |            |            |            |
| 75               | 13,900                                    |            |            |            |                  |   |            |            |            |
| 80               | 12,800                                    |            |            |            |                  |   |            |            |            |
| 85               | 11,700                                    |            |            |            |                  |   |            |            |            |
| 90               | 10,800                                    |            |            |            |                  |   |            |            |            |
| 95               | 10,000                                    |            |            |            |                  |   |            |            |            |
| 100              | 9,200                                     |            |            |            |                  |   |            |            |            |
| 105              | 8,500                                     |            |            |            |                  |   |            |            |            |
| 110              | 7,900                                     |            |            |            |                  |   |            |            |            |
| 115              | 7,000                                     |            |            |            |                  |   |            |            |            |
| 120              | 6,300                                     |            |            |            |                  |   |            |            |            |
| 125              | 5,600                                     |            |            |            |                  |   |            |            |            |
| 130              | 4,900                                     |            |            |            |                  |   |            |            |            |
| 135              | 4,300                                     |            |            |            |                  |   |            |            |            |
| 140              | 3,800                                     |            |            |            |                  |   |            |            |            |
| 145              | 3,300                                     |            |            |            |                  |   |            |            |            |
| 150              |   |            |            |            |                  |   |            |            |            |
| 155              |   |            |            |            |                  |   |            |            |            |
| 160              |   |            |            |            |                  |   |            |            |            |
| 165              |   |            |            |            |                  |   |            |            |            |
| 170              |   |            |            |            |                  |   |            |            |            |
| Telescoping mode | 1   | 2          | 1          | 2          | Telescoping mode | 1   | 2          | 1          | 2          |

B: Load radius in feet



# SMART COUNTERWEIGHT

You can increase the capacity by changing the mounting position of the counterweight.

SMART CW 1 status

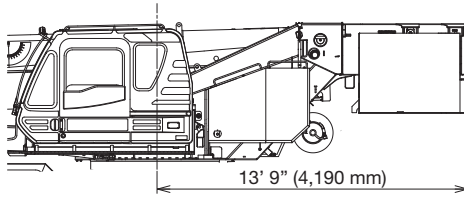

SMART CW 2 status

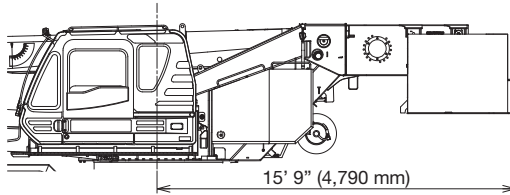

- SMART CW 1: Counterweight is mounted at the front.
- SMART CW 2: Counterweight is mounted at the rear.

# WARNING AND OPERATING INSTRUCTIONS FOR LIFTING CAPACITIES

## GENERAL

1. RATED LIFTING CAPACITIES apply only to the machine as originally manufactured and normally equipped by TADANO LTD. Modifications to the machine or use of optional equipment other than that specified can result in a reduction of capacity.
2. Hydraulic cranes can be hazardous if improperly operated or maintained. Operation and maintenance of this machine must be in compliance with information, in the Operation Manual supplied with the crane. If this manual is missing, order a replacement through the distributor.
3. The operator and other personnel associated with this machine shall fully acquaint themselves with the latest American National Standards Institute (ANSI) safety standards for cranes.

## SET UP

1. Rated lifting capacities on the chart are the maximum allowable crane capacities and are based on the machine standing level on firm supporting surface under ideal job conditions. Depending on the nature of the supporting surface, it may be necessary to have structural supports under the outrigger floats or tires to spread the loads to a larger bearing surface.
2. For outrigger operation, outriggers shall be properly extended with tires free of supporting surface before operating crane.

## OPERATION

1. Rated lifting capacities have been tested to and meet minimum requirements of SAE J1063-Cantilevered Boom Crane Structures Method of Test.  
Rated lifting capacities do not exceed 85% of the tipping load on outriggers fully extended as determined by SAE J765-Crane Stability Test Code.
2. Rated lifting capacities for partially extended outriggers are determined from the formula, Rated Lifting Capacities = (Tipping Load - 0.1 × Tip Reaction) / 1.25.
3. Rated lifting capacities are based on actual load radius increased by boom deflection.
4. The weight of handling device such as hook blocks, slings, etc., must be considered as part of the load and must be deducted from the lifting capacities.
5. Rated lifting capacities are based on freely suspended loads and make no allowance for such factors as the effect of wind, sudden stopping of loads, supporting surface conditions, inflation of tires, operating speeds, side loads, etc. Side pull on boom or jib is extremely dangerous.  
Such action can damage the boom, jib or slewing mechanism, and lead to overturning of the crane.
6. Rated lifting capacities do not account for wind on lifted load or boom. We recommend against working under the condition that the load is out of control due to a strong wind. During boom lift, consider that the rated lifting capacity is reduced by 50% when the wind speed is 20 mph (9 m/s) to 27 mph (12 m/s); reduced by 70% when the wind speed is 27 mph (12 m/s) to 31 mph (14 m/s). If the wind speed is 31 mph (14 m/s) or over, stop operation. During jib lift, stop operation if the wind speed is 20 mph (9 m/s) or over.
7. Rated lifting capacities at load radius shall not be exceeded. Do not tip the crane to determine allowable loads.
8. Do not operate at boom lengths, radii, or boom angle, where no capacities are shown. Crane may overturn without any load on the hook.
9. When boom length is between values listed, refer to the rated lifting capacities of the next longer and next shorter booms for the same radius. The lesser of the two rated lifting capacities shall be used.
10. When making lifts at a load radius not shown, use the next longer radius to determine allowable capacity.
11. Load per line should not exceed 14,600 lbs. (6,600 kg) for main winch and auxiliary winch.
12. Check the actual number of parts of line with LOAD MOMENT INDICATOR (AML-E2) before operation. Maximum lifting capacity is restricted by the number of parts of line of LOAD MOMENT INDICATOR (AML-E2). Limited capacity is as determined from the formula, Single line pull for main winch 14,600 lbs. (6,600 kg) × number of parts of line.

13. The boom angle before loading should be greater to account for deflection. For rated lifting capacities, the loaded boom angle and the load radius is for reference only.
14. The 42.0' (12.8 m) boom length capacities are based on boom fully retracted. If not fully retracted [less than 57.7' (17.6 m) boom length], use the rated lifting capacities for the 57.7' (17.6 m) boom length.
15. Extension or retraction of the boom with loads may be attempted within the limits of the RATED LIFTING CAPACITIES.  
The ability to telescope loads is limited by hydraulic pressure, boom angle, boom length, crane maintenance, etc.  
For lifting capacity of single top, deduct the weight of the load handling equipment from the rated lifting capacity of the boom.
16. For the lifting capacity of single top, the net capacity shall not exceed 14,600 lbs. (6,600 kg) including the main boom hook mass attached to the boom.
17. When the base jib or top jib or both jibs are removed, set the jib state switch to the REMOVED position.
18. When erecting and stowing jib, be sure to retain it by hand or by other means to prevent its free movement.
19. Use "ANTI-TWOBLOCK" disable switch when erecting and stowing jib and when stowing hook block. While the switch is pushed, the hoist does not stop, even when overwind condition occurs.
20. When lifting a load by using jib (aux. winch) and boom (main winch) simultaneously, do the following:
  - Enter the operation status as jib operation, not as boom operation.
  - Before starting operation, make sure that mass of load is within rated lifting capacity for jib.
21. Before telescoping the boom, set the telescoping mode selector switch to mode 1 or mode 2 fully retracted.  
A change of the telescoping mode is not permissible when the boom has been partially or fully extended.
22. Crane operation is prohibited without full counterweight 24,700 lbs. (11.2 ton) installed. Outriggers shall be extended 23' 11-3 / 8" (7.3 m) spread when installing or removing removable counterweight.

## DEFINITIONS

1. Load Radius: Horizontal distance from a projection of the axis of rotation to supporting surface before loading to the center of the vertical hoist line or tackle with load applied.
2. Loaded Boom Angle: The angle between the boom base section and the horizontal, after lifting the rated lifting capacity at the load radius.
3. Working Area: Area measured in a circular arc about the centerline of rotation.
4. Freely Suspended Load: Load hanging free with no direct external force applied except by the hoist line.
5. Side Load: Horizontal side force applied to the lifted load either on the ground or in the air.

# GR-1000XLL-4 RATED LIFTING CAPACITIES (IN POUNDS)

| COUNTERWEIGHT 24,700lbs (11.2 t)<br>ON RUBBER STATIONARY<br>SMART CW1 |                   |                   |                   |                    |                  |                   |                   |                   |                    |
|---|-------------------|-------------------|-------------------|--------------------|------------------|-------------------|-------------------|-------------------|--------------------|
| Over front  |                   |                   |                   |                    | 360° Rotation    |                   |                   |                   |                    |
| B \ A   | 42.0'<br>(12.8 m) | 73.3'<br>(22.4 m) | 89.0'<br>(27.1 m) | 104.7'<br>(31.9 m) | B \ A            | 42.0'<br>(12.8 m) | 73.3'<br>(22.4 m) | 89.0'<br>(27.1 m) | 104.7'<br>(31.9 m) |
| 12  | 65,000            |                   |                   |                    | 12               | 43,000            |                   |                   |                    |
| 15  | 53,700            |                   |                   |                    | 15               | 32,600            |                   |                   |                    |
| 20  | 40,400            | 33,800            | 29,700            |                    | 20               | 19,400            | 22,900            | 22,900            |                    |
| 25  | 31,400            | 33,800            | 29,700            | 27,700             | 25               | 12,500            | 15,700            | 16,400            | 16,800             |
| 30  | 24,200            | 27,300            | 27,800            | 27,700             | 30               | 8,100             | 11,200            | 11,800            | 12,200             |
| 35  |                   | 21,200            | 21,700            | 22,000             | 35               |                   | 8,100             | 8,700             | 9,100              |
| 40  |                   | 16,800            | 17,400            | 17,800             | 40               |                   | 5,800             | 6,400             | 6,800              |
| 45  |                   | 13,600            | 14,200            | 14,500             | 45               |                   | 4,100             | 4,700             | 5,100              |
| 50  |                   | 11,100            | 11,600            | 12,000             | 50               |                   | 2,800             | 3,400             | 3,700              |
| 55  |                   | 9,100             | 9,700             | 10,000             | 55               |                   | 1,700             | 2,300             | 2,600              |
| 60  |                   | 7,500             | 8,000             | 8,400              | 60               |                   |                   |                   |                    |
| 65  |                   | 6,200             | 6,700             | 7,100              | 65               |                   |                   |                   |                    |
| 70  |                   |                   | 5,600             | 5,900              | 70               |                   |                   |                   |                    |
| 75  |                   |                   | 4,700             | 5,000              | 75               |                   |                   |                   |                    |
| 80  |                   |                   | 3,900             | 4,200              | 80               |                   |                   |                   |                    |
| 85  |                   |                   |                   | 3,400              | 85               |                   |                   |                   |                    |
| 90  |                   |                   |                   | 2,800              | 90               |                   |                   |                   |                    |
| 95  |                   |                   |                   | 2,300              | 95               |                   |                   |                   |                    |
| D   | 0°                |                   |                   |                    | D                | 0°                | 29°               | 43°               | 50°                |
| Telescoping mode  | 1, 2              | 2                 | 2                 | 2                  | Telescoping mode | 1, 2              | 2                 | 2                 | 2                  |
| 2nd Boom  | 0                 | 0                 | 0                 | 0                  | 2nd Boom         | 0                 | 0                 | 0                 | 0                  |
| 3rd Boom  | 0                 | 33                | 50                | 67                 | 3rd Boom         | 0                 | 33                | 50                | 67                 |
| 4th Boom  | 0                 | 33                | 50                | 67                 | 4th Boom         | 0                 | 33                | 50                | 67                 |
| Top Boom  | 0                 | 33                | 50                | 67                 | Top Boom         | 0                 | 33                | 50                | 67                 |

| COUNTERWEIGHT 24,700lbs (11.2 t)<br>ON RUBBER STATIONARY<br>SMART CW1 |                   |        |                   |       |                   |       |                    |       |  |
|---|-------------------|--------|-------------------|-------|-------------------|-------|--------------------|-------|--|
| C \ A   | 42.0'<br>(12.8 m) |        | 73.3'<br>(22.4 m) |       | 89.0'<br>(27.1 m) |       | 104.7'<br>(31.9 m) |       |  |
| 0°  | 35.2              | 18,400 | 66.1              | 5,100 | 81.8              | 3,300 | 97.2               | 2,200 |  |
| C \ A   | 42.0'<br>(12.8 m) |        |                   |       |                   |       |                    |       |  |
| 0°  | 35.2              | 5,100  |                   |       |                   |       |                    |       |  |

| COUNTERWEIGHT 24,700lbs (11.2 t)<br>ON RUBBER CREEP<br>SMART CW1 |                   |                   |                   |                    |  |  |  |  |  |
|--|-------------------|-------------------|-------------------|--------------------|--|--|--|--|--|
| Over front   |                   |                   |                   |                    |  |  |  |  |  |
| B \ A  | 42.0'<br>(12.8 m) | 73.3'<br>(22.4 m) | 89.0'<br>(27.1 m) | 104.7'<br>(31.9 m) |  |  |  |  |  |
| 12   | 50,600            |                   |                   |                    |  |  |  |  |  |
| 15   | 41,400            |                   |                   |                    |  |  |  |  |  |
| 20   | 30,400            | 33,300            | 29,700            |                    |  |  |  |  |  |
| 25   | 23,200            | 26,100            | 26,700            | 27,000             |  |  |  |  |  |
| 30   | 17,900            | 20,900            | 21,500            | 21,900             |  |  |  |  |  |
| 35   |                   | 17,000            | 17,600            | 17,900             |  |  |  |  |  |
| 40   |                   | 13,900            | 14,500            | 14,900             |  |  |  |  |  |
| 45   |                   | 11,400            | 12,000            | 12,400             |  |  |  |  |  |
| 50   |                   | 9,400             | 10,000            | 10,400             |  |  |  |  |  |
| 55   |                   | 7,700             | 8,300             | 8,700              |  |  |  |  |  |
| 60   |                   | 6,300             | 6,900             | 7,300              |  |  |  |  |  |
| 65   |                   | 5,100             | 5,700             | 6,100              |  |  |  |  |  |
| 70   |                   |                   | 4,700             | 5,000              |  |  |  |  |  |
| 75   |                   |                   | 3,800             | 4,100              |  |  |  |  |  |
| 80   |                   |                   | 3,000             | 3,300              |  |  |  |  |  |
| 85   |                   |                   |                   | 2,600              |  |  |  |  |  |
| 90   |                   |                   |                   | 2,000              |  |  |  |  |  |
| 95   |                   |                   |                   | 1,500              |  |  |  |  |  |
| D  | 0°                |                   |                   |                    |  |  |  |  |  |
| Telescoping mode   | 1, 2              | 2                 | 2                 | 2                  |  |  |  |  |  |
| 2nd Boom   | 0                 | 0                 | 0                 | 0                  |  |  |  |  |  |
| 3rd Boom   | 0                 | 33                | 50                | 67                 |  |  |  |  |  |
| 4th Boom   | 0                 | 33                | 50                | 67                 |  |  |  |  |  |
| Top Boom   | 0                 | 33                | 50                | 67                 |  |  |  |  |  |

| COUNTERWEIGHT 24,700lbs (11.2 t)<br>ON RUBBER CREEP<br>SMART CW1 |                   |        |                   |       |                   |       |                    |       |  |
|--|-------------------|--------|-------------------|-------|-------------------|-------|--------------------|-------|--|
| C \ A  | 42.0'<br>(12.8 m) |        | 73.3'<br>(22.4 m) |       | 89.0'<br>(27.1 m) |       | 104.7'<br>(31.9 m) |       |  |
| 0°   | 35.2              | 13,800 | 66.1              | 4,200 | 81.8              | 2,400 | 97.2               | 1,400 |  |
| C \ A  | 42.0'<br>(12.8 m) |        |                   |       |                   |       |                    |       |  |
| 0°   | 35.2              | 5,100  |                   |       |                   |       |                    |       |  |

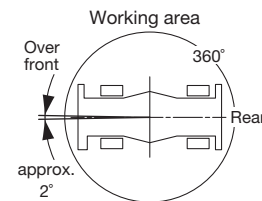

- A: Boom length in feet
- B: Load radius in feet
- C: Loaded boom angle (°)
- D: Minimum boom angle (°) for indicated length (no load)

NOTE: The lifting capacity data stored in the LOAD MOMENT INDICATOR (AML-E2) is based on the standard number of parts of line listed in the chart.  
Standard number of parts of line for on-rubber operation should be according to the chart.

| Boom length in feet (meters) | 42.0'<br>(12.8 m) | 42.0' to 104.7'<br>(12.8 m to 31.9 m) | Single top jib |
|------------------------------|-------------------|---------------------------------------|----------------|
| Number of parts of line      | 6                 | 4                                     | 1              |

# GR-1000XLL-4 RATED LIFTING CAPACITIES (IN POUNDS)

| COUNTERWEIGHT 24,700lbs (11.2 t)<br>ON RUBBER STATIONARY<br>SMART CW2 |      |                   |                   |                   |                    |      |    |                   |                   |                   |                    |
|---|------|-------------------|-------------------|-------------------|--------------------|------|----|-------------------|-------------------|-------------------|--------------------|
| Over front  |      |                   |                   |                   | 360° Rotation      |      |    |                   |                   |                   |                    |
| B   | A    | 42.0'<br>(12.8 m) | 73.3'<br>(22.4 m) | 89.0'<br>(27.1 m) | 104.7'<br>(31.9 m) | B    | A  | 42.0'<br>(12.8 m) | 73.3'<br>(22.4 m) | 89.0'<br>(27.1 m) | 104.7'<br>(31.9 m) |
|   | 12   |                   | 67,600            |                   |                    |      |    | 12                |                   |                   |                    |
| 15  |      | 56,000            |                   |                   |                    | 15   |    |                   |                   |                   |                    |
| 20  |      | 42,300            | 33,800            | 29,700            |                    | 20   |    | 21,800            |                   |                   |                    |
| 25  |      | 33,000            | 33,800            | 29,700            | 27,700             | 25   |    | 14,200            | 17,500            |                   |                    |
| 30  |      | 25,900            | 29,000            | 29,400            | 27,700             | 30   |    | 9,500             | 12,600            | 13,200            | 13,200             |
| 35  |      |                   | 22,600            | 23,000            | 23,300             | 35   |    |                   | 9,300             | 9,900             | 10,300             |
| 40  |      |                   | 18,000            | 18,600            | 18,800             | 40   |    |                   | 6,900             | 7,500             | 7,900              |
| 45  |      |                   | 14,600            | 15,200            | 15,500             | 45   |    |                   | 5,000             | 5,600             | 6,000              |
| 50  |      |                   | 12,000            | 12,500            | 12,900             | 50   |    |                   | 3,600             | 4,200             | 4,600              |
| 55  |      |                   | 9,900             | 10,500            | 10,800             | 55   |    |                   | 2,500             | 3,000             | 3,400              |
| 60  |      |                   | 8,200             | 8,800             | 9,100              | 60   |    |                   | 1,500             | 2,100             | 2,400              |
| 65  |      |                   | 6,900             | 7,400             | 7,700              | 65   |    |                   |                   | 1,300             |                    |
| 70  |      |                   |                   | 6,200             | 6,500              | 70   |    |                   |                   |                   |                    |
| 75  |      |                   |                   | 5,200             | 5,600              | 75   |    |                   |                   |                   |                    |
| 80  |      |                   |                   | 4,400             | 4,700              | 80   |    |                   |                   |                   |                    |
| 85  |      |                   |                   |                   | 3,900              | 85   |    |                   |                   |                   |                    |
| 90  |      |                   |                   |                   | 3,300              | 90   |    |                   |                   |                   |                    |
| 95  |      |                   |                   |                   | 2,800              | 95   |    |                   |                   |                   |                    |
| D   | 0°   |                   |                   |                   | D                  | 0°   |    |                   |                   |                   |                    |
| Telescoping mode  | 1, 2 | 2                 | 2                 | 2                 | Telescoping mode   | 1, 2 | 2  | 2                 | 2                 |                   |                    |
| 2nd Boom  | 0    | 0                 | 0                 | 0                 | 2nd Boom           | 0    | 0  | 0                 | 0                 |                   |                    |
| 3rd Boom  | 0    | 33                | 50                | 67                | 3rd Boom           | 0    | 33 | 50                | 67                |                   |                    |
| 4th Boom  | 0    | 33                | 50                | 67                | 4th Boom           | 0    | 33 | 50                | 67                |                   |                    |
| Top Boom  | 0    | 33                | 50                | 67                | Top Boom           | 0    | 33 | 50                | 67                |                   |                    |

| COUNTERWEIGHT 24,700lbs (11.2 t)<br>ON RUBBER STATIONARY<br>SMART CW2 |   |                   |          |                   |          |                   |          |                    |          |
|---|---|-------------------|----------|-------------------|----------|-------------------|----------|--------------------|----------|
| C   | A | 42.0'<br>(12.8 m) |          | 73.3'<br>(22.4 m) |          | 89.0'<br>(27.1 m) |          | 104.7'<br>(31.9 m) |          |
|   |   | B                 | (12.8 m) | B                 | (22.4 m) | B                 | (27.1 m) | B                  | (31.9 m) |
| 0°  |   | 35.2              | 19,900   | 66.1              | 5,700    | 81.8              | 3,700    | 97.2               | 2,600    |
| 0°  |   | 35.2              | 6,200    |                   |          |                   |          |                    |          |

| COUNTERWEIGHT 24,700lbs (11.2 t)<br>ON RUBBER CREEP<br>SMART CW2 |      |                   |                   |                   |                    |  |  |  |  |
|--|------|-------------------|-------------------|-------------------|--------------------|--|--|--|--|
| Over front   |      |                   |                   |                   |                    |  |  |  |  |
| B  | A    | 42.0'<br>(12.8 m) | 73.3'<br>(22.4 m) | 89.0'<br>(27.1 m) | 104.7'<br>(31.9 m) |  |  |  |  |
|  | 12   |                   | 53,300            |                   |                    |  |  |  |  |
| 15   |      | 43,600            |                   |                   |                    |  |  |  |  |
| 20   |      | 32,300            | 33,800            | 29,700            |                    |  |  |  |  |
| 25   |      | 24,800            | 27,600            | 28,200            | 27,700             |  |  |  |  |
| 30   |      | 19,300            | 22,300            | 22,900            | 23,200             |  |  |  |  |
| 35   |      |                   | 18,100            | 18,700            | 19,100             |  |  |  |  |
| 40   |      |                   | 14,900            | 15,500            | 15,900             |  |  |  |  |
| 45   |      |                   | 12,300            | 12,900            | 13,300             |  |  |  |  |
| 50   |      |                   | 10,200            | 10,800            | 11,200             |  |  |  |  |
| 55   |      |                   | 8,500             | 9,100             | 9,500              |  |  |  |  |
| 60   |      |                   | 7,000             | 7,600             | 8,000              |  |  |  |  |
| 65   |      |                   | 5,800             | 6,400             | 6,800              |  |  |  |  |
| 70   |      |                   |                   | 5,300             | 5,700              |  |  |  |  |
| 75   |      |                   |                   | 4,400             | 4,700              |  |  |  |  |
| 80   |      |                   |                   | 3,600             | 3,900              |  |  |  |  |
| 85   |      |                   |                   |                   | 3,200              |  |  |  |  |
| 90   |      |                   |                   |                   | 2,500              |  |  |  |  |
| 95   |      |                   |                   |                   | 2,000              |  |  |  |  |
| D  | 0°   |                   |                   |                   |                    |  |  |  |  |
| Telescoping mode   | 1, 2 | 2                 | 2                 | 2                 |                    |  |  |  |  |
| 2nd Boom   | 0    | 0                 | 0                 | 0                 |                    |  |  |  |  |
| 3rd Boom   | 0    | 33                | 50                | 67                |                    |  |  |  |  |
| 4th Boom   | 0    | 33                | 50                | 67                |                    |  |  |  |  |
| Top Boom   | 0    | 33                | 50                | 67                |                    |  |  |  |  |

| COUNTERWEIGHT 24,700lbs (11.2 t)<br>ON RUBBER CREEP<br>SMART CW2 |   |                   |          |                   |          |                   |          |                    |          |
|--|---|-------------------|----------|-------------------|----------|-------------------|----------|--------------------|----------|
| C  | A | 42.0'<br>(12.8 m) |          | 73.3'<br>(22.4 m) |          | 89.0'<br>(27.1 m) |          | 104.7'<br>(31.9 m) |          |
|  |   | B                 | (12.8 m) | B                 | (22.4 m) | B                 | (27.1 m) | B                  | (31.9 m) |
| 0°   |   | 35.2              | 14,700   | 66.1              | 4,800    | 81.8              | 3,000    | 97.2               | 1,900    |

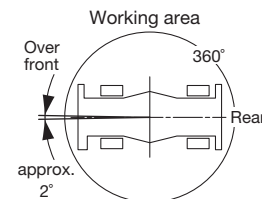

- A: Boom length in feet
- B: Load radius in feet
- C: Loaded boom angle (°)
- D: Minimum boom angle (°) for indicated length (no load)

NOTE: The lifting capacity data stored in the LOAD MOMENT INDICATOR (AML-E2) is based on the standard number of parts of line listed in the chart.  
Standard number of parts of line for on-rubber operation should be according to the chart.

| Boom length in feet (meters) | 42.0'<br>(12.8 m) | 42.0' to 104.7'<br>(12.8 m to 31.9 m) | Single top jib |
|------------------------------|-------------------|---------------------------------------|----------------|
| Number of parts of line      | 6                 | 4                                     | 1              |

# WARNING AND OPERATING INSTRUCTIONS FOR ON RUBBER LIFTING CAPACITIES

- Rated lifting capacities on-rubber are in pounds and do not exceed 75% of tipping loads as determined by SAE J765-Crane Stability Test Code.
- Rated lifting capacities shown in the chart are based on condition that crane is set on firm level surfaces with suspension-lock applied. They are based on actual load radius increased by tire deformation and boom deflection.
- If the suspension-lock cylinders contain air, the axle will not be locked completely and rated lifting capacities may not be obtainable. Bleed the cylinders according to the operation safety and maintenance manual.
- Rated lifting capacities are based on proper tire inflation, capacity and condition. Damaged tires are hazardous to safe operation of crane.
- Tires shall be inflated to correct air pressure.
- Over front operation shall be performed within 2 degrees in front of chassis.
- On-rubber lifting with "jib" is not permitted. Maximum permissible boom length is 104.7 ft. (31.9 m).
- When making lift on-rubber stationary, set parking brake.
- For creep operation, boom must be centered over front of machine, slewing lock engaged, and load restrained from slewing. Travel slowly and keep the lifted load as close to the ground as possible, and especially avoid any abrupt steering, accelerating or braking.
- Do not operate the crane while carrying the load.
- Creep is motion for crane not to travel more than 200 ft. (60 m) in any 30 minute period and to travel at the speed of less than 1 mph (1.6 km/h).
- For creep operation, choose the drive mode and proper gear according to the road or working condition.

| Tires        | Air Pressure      |
|--------------|-------------------|
| 29.5-25 36PR | 68 psi. (470 kPa) |
| 29.5-25 40PR | 67 psi. (465 kPa) |

## NOTES FOR LOAD MOMENT INDICATOR (AML-E2)

- Set AML select keys in accordance with the actually operating crane conditions and don't fail to make sure, before crane operation, that the displays on front panel are correct.
- When operating crane on outriggers:
  - Set "P.T.O." switch to "ON".
  - Press the outrigger state select key to register for the outrigger operation. If the display agrees with the actual state, press the set key to register. After the completion of the registration, the display returns to the crane operation status.
  - Press the lift state select key to register the lift state to be used (single top/jib/boom).
  - Each time the lift state select key is pressed, the display changes. If the display agrees with the actual state, press the set key to register. After the completion of the registration, the display returns to the crane operation status.
  - When erecting and stowing jib, select the status of jib set (Jib state indicative symbol lights up).
- When operating crane on-rubber:
  - Set "P.T.O." switch to "ON".
  - Press the outrigger state select key to register for the on-rubber operation. Each time the outrigger state select key is pressed, the display changes. Select the creep operation, the on-rubber state indicator symbol lights up.
  - Press the lift state select key to register the lift state. However, pay attention to the following.
    - For stationary operation.
      - The front capacities are attainable only when the over front position symbol comes on.
      - When the boom is more than 2 degrees from centered over front of chassis, 360° capacities are in effect.
      - When a load is lifted in the front position and then slewed to the side area, make sure the value of the LOAD MOMENT INDICATOR (AML-E2) is below the 360° lifting capacity.
    - For creep operation.
      - The creep capacities are attainable only when boom is in the straight forward position of chassis and the over front position symbol is on. If boom is not in the straight forward position of chassis, never lift load.
- This machine is equipped with an automatic slewing stopping device. (For the details, see Operation Manual.) But, operate very carefully because the automatic slewing stop does not work in the following cases.
  - During on-rubber operation.
  - When the "P.T.O." switch is set to "OVERRIDE" and the "OVERRIDE" key switch outside the cab is on.
- During crane operation, make sure that the displays on front panel are in accordance with actual operating conditions.
- The displayed values of LOAD MOMENT INDICATOR (AML-E2) are based on freely suspended loads and make no allowance for such factors as the effect of wind, sudden stopping of loads, supporting surface conditions, inflation of tire, operating speed, side loads, etc.  
For safe operation, it is recommended when extending and lowering boom or slewing, lifting loads shall be appropriately reduced.
- LOAD MOMENT INDICATOR (AML-E2) is intended as an aid to the operator. Under no condition should it be relied upon to replace use of capacity charts and operating instruction. Sole reliance upon LOAD MOMENT INDICATOR (AML-E2) aids in place of good operating practice can cause an accident. The operator must exercise caution to assure safety.
- The lifting capacity differs depending on the outrigger extension width and slewing position.  
Work with the capacity corresponding to the outrigger extension width and slewing position.  
For the relationship among the outrigger extension width, slewing position and lifting capacities, refer to the working area charts.

## GR-1000XLL-4 AXLE WEIGHT DISTRIBUTION CHART

|   | Pounds  |        |         | Kilograms |        |         |
|---|---------|--------|---------|-----------|--------|---------|
|   | GVW     | Front  | Rear    | GVW       | Front  | Rear    |
| Base machine                            | 123,500 | 61,600 | 61,900  | 56,040    | 27,940 | 28,100  |
| Remove:                                 |         |        |         |           |        |         |
| 1. 7.3 ton (6.6 metric ton) hook block  | -400    | -600   | 200     | -165      | -251   | 86      |
| 2. 100 ton (90.7 metric ton) hook block | -1,900  | -3,500 | 1,600   | -850      | -1,571 | 721     |
| 3. Top jib                              | -800    | -1,200 | 400     | -336      | -534   | 198     |
| 4. Base jib                             | -2,000  | -4,200 | 2,200   | -867      | -1,886 | 1,019   |
| 5. Removable Counterweight              | -24,700 | 9,500  | -34,200 | -11,200   | 4,296  | -15,496 |







**TADANO AMERICA CORPORATION**

4242 West Greens Road.  
Houston, Texas, 77066 U.S.A.  
PHONE: (281) 869-0030  
FAX: (281) 869-0040  
<http://www.tadanoamerica.com>