

AC 4.080-1

88 US TON MAX. CRANE CAPACITY

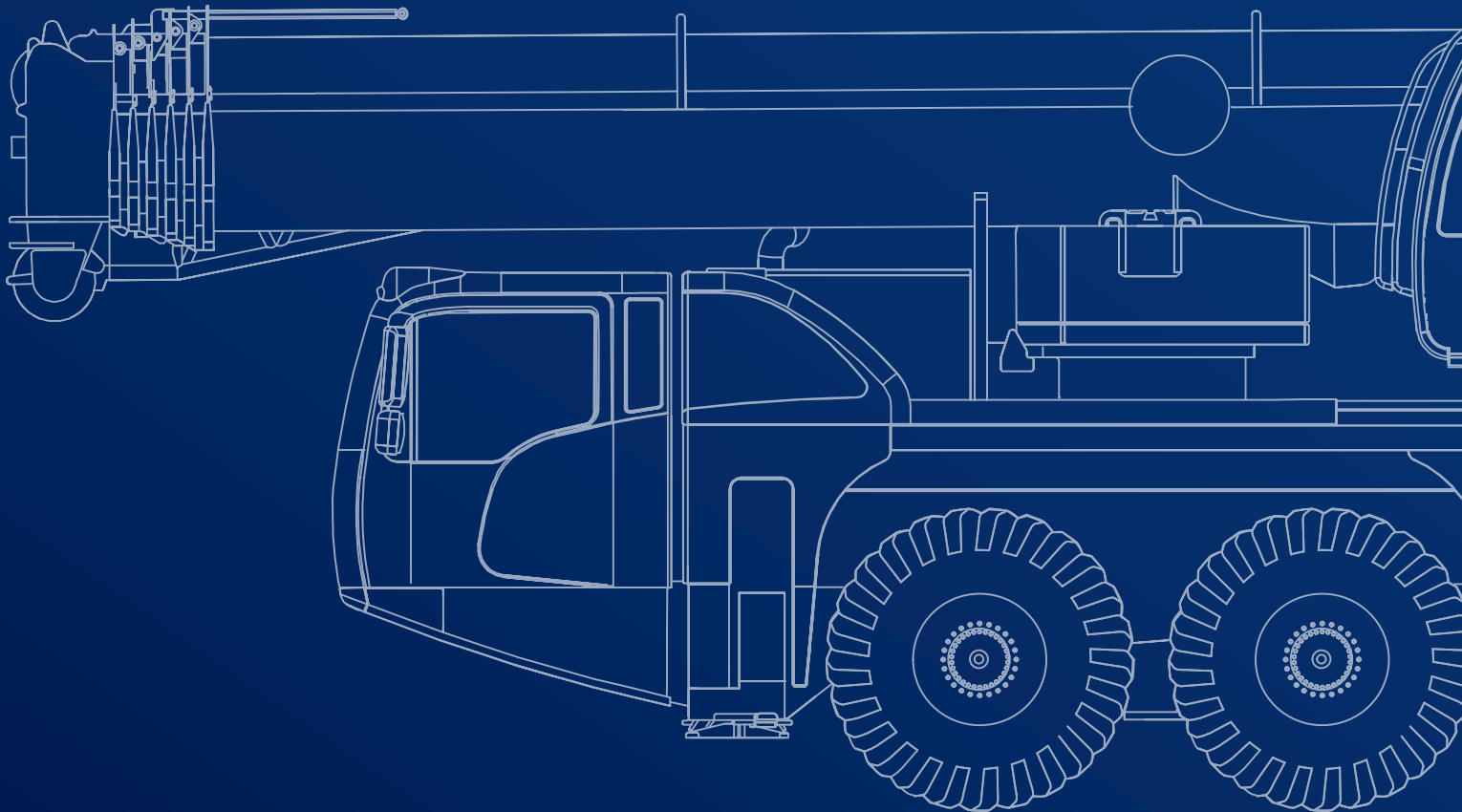

February 2023. Unless otherwise specified, all information in this brochure refers to a standard crane equipment, and it is intended as general information only. No liability is assumed. Errors reserved. Product specifications and prices are subject to changes without notice. The photographs and/or drawings in this brochure are for illustrative purposes only. For correct and safe crane operation, the original operating manual and lifting capacity charts are essential. Failure to follow the corresponding Operator's Manual when using our equipment or failure to otherwise act responsibly may result in property damage, serious injury or death. The sole warranty applicable with respect to our equipment is the standard warranty as per general terms and conditions of sales and service (ask your local Tadano dealer for details), and Tadano makes no other warranty, express or implied. All rights reserved. Any use of the trademarks, logos, brand names and model names used herein is prohibited.

© Tadano Ltd. 2023

Contents

General	5
Vehicle dimensions	6
Boom combinations	7
On-road and off-road driving	9
Axle loads	10
Speeds and gradeability	10
Steering	10
Transportation	11
Counterweight	12-13
Configurations	12
Jib	14
Operation	15
Main boom	17
Slewing	17
Hoist	17
Outrigger cylinders	17
Hook Blocks	17
HA: Main boom	18-25
HAV: Folding swing-away jib	26-35
MS: Montagespitze	36-39
Notes to Lifting Capacity	40
Technical Description	41
Basic machine	42
Additional equipment	43

Key



	Counterweight		Dolly
	Lifting capacities on outriggers · 360°		Working speeds
	Radius		Slewing
	Main boom		Max. line pull
	Folding swing-away jib		Rope diameter
	Runner		Rope length
	Max. axle loads		Hook block
	Mechanism		Number of lines
	Tires		Possible load of hook block
	Hook block		Weight of hook block
	Hoist		Distance head sheave axle – hook ground
	Travel speed		Number of sheaves in hook block
	Gradeability		Max. outrigger load
	Off road / On road		Length of stroke (support cylinders)
	Boom telescoping		Payload incl. rear storage box
	Boom elevation		

GENERAL TECHNICAL DATA

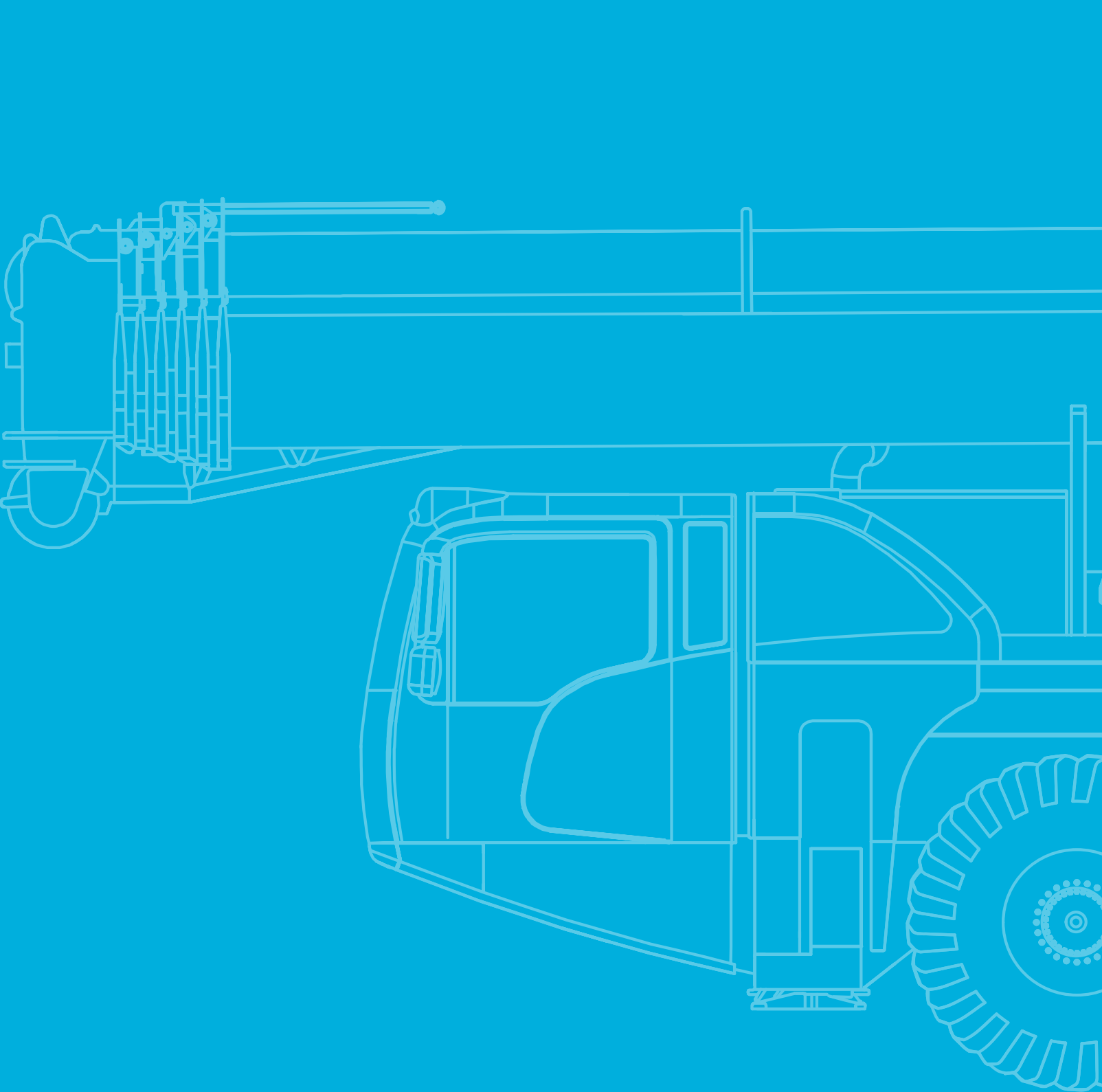

General

Vehicle dimensions

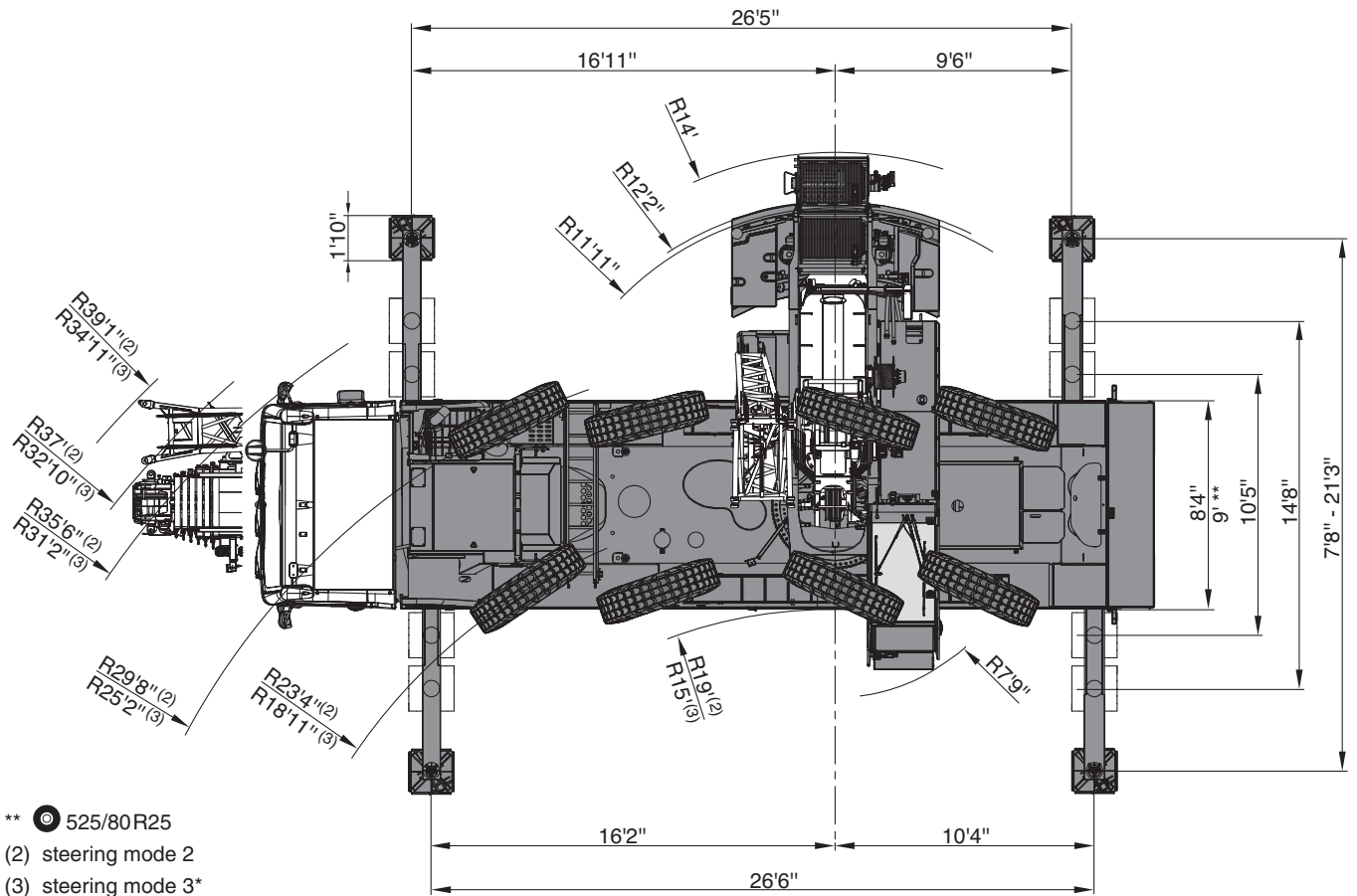
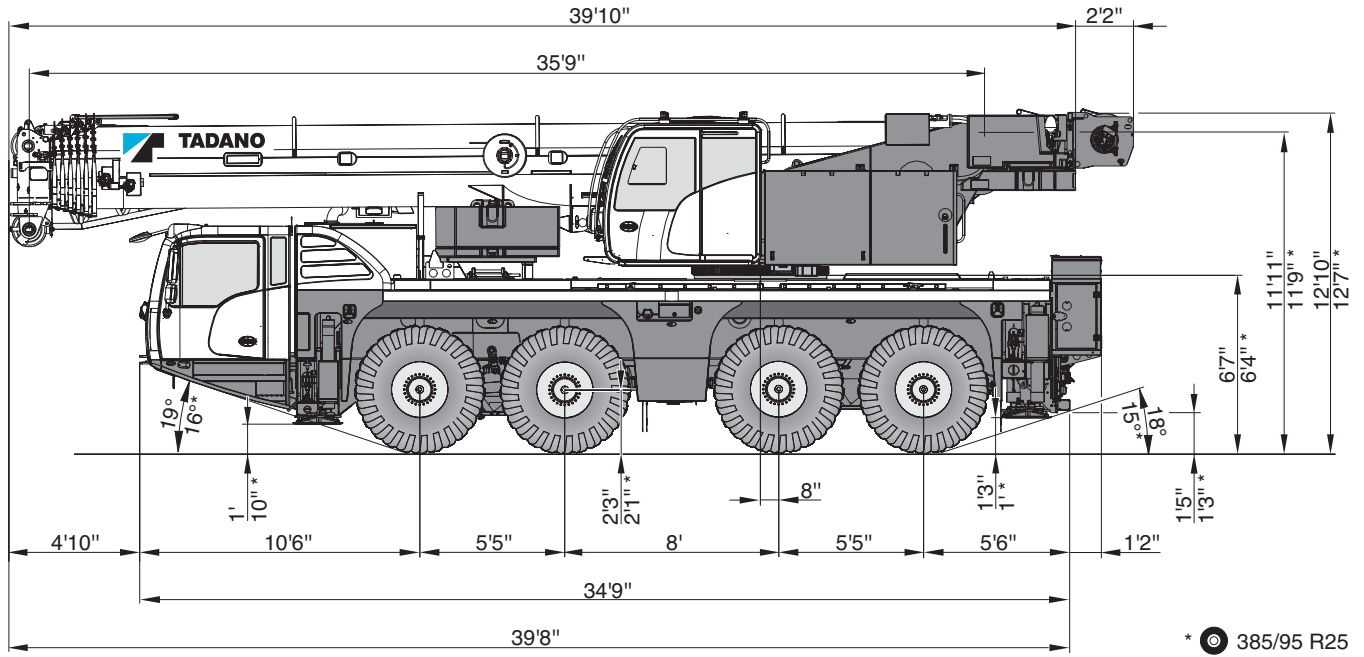

General

Boom Combinations

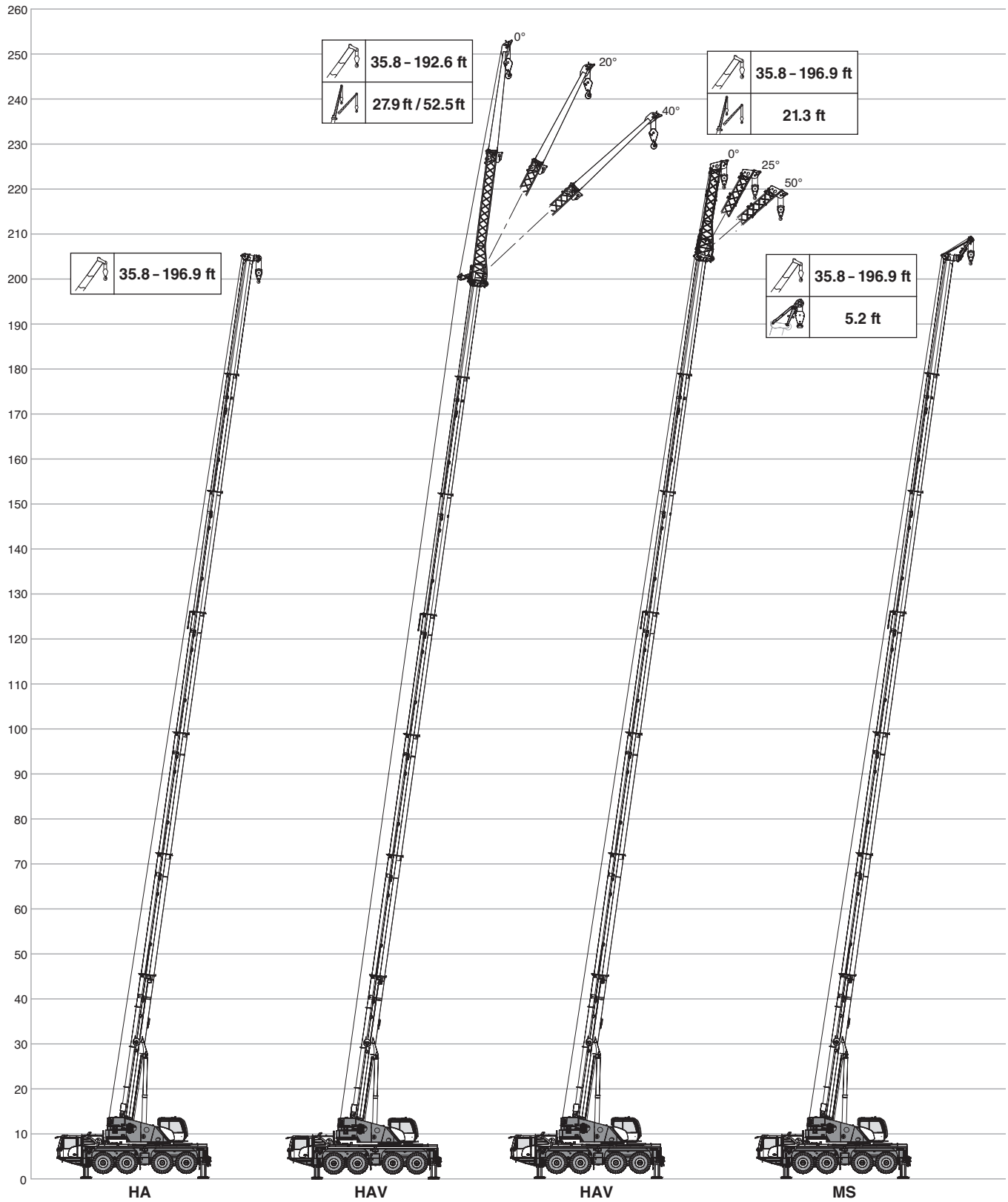



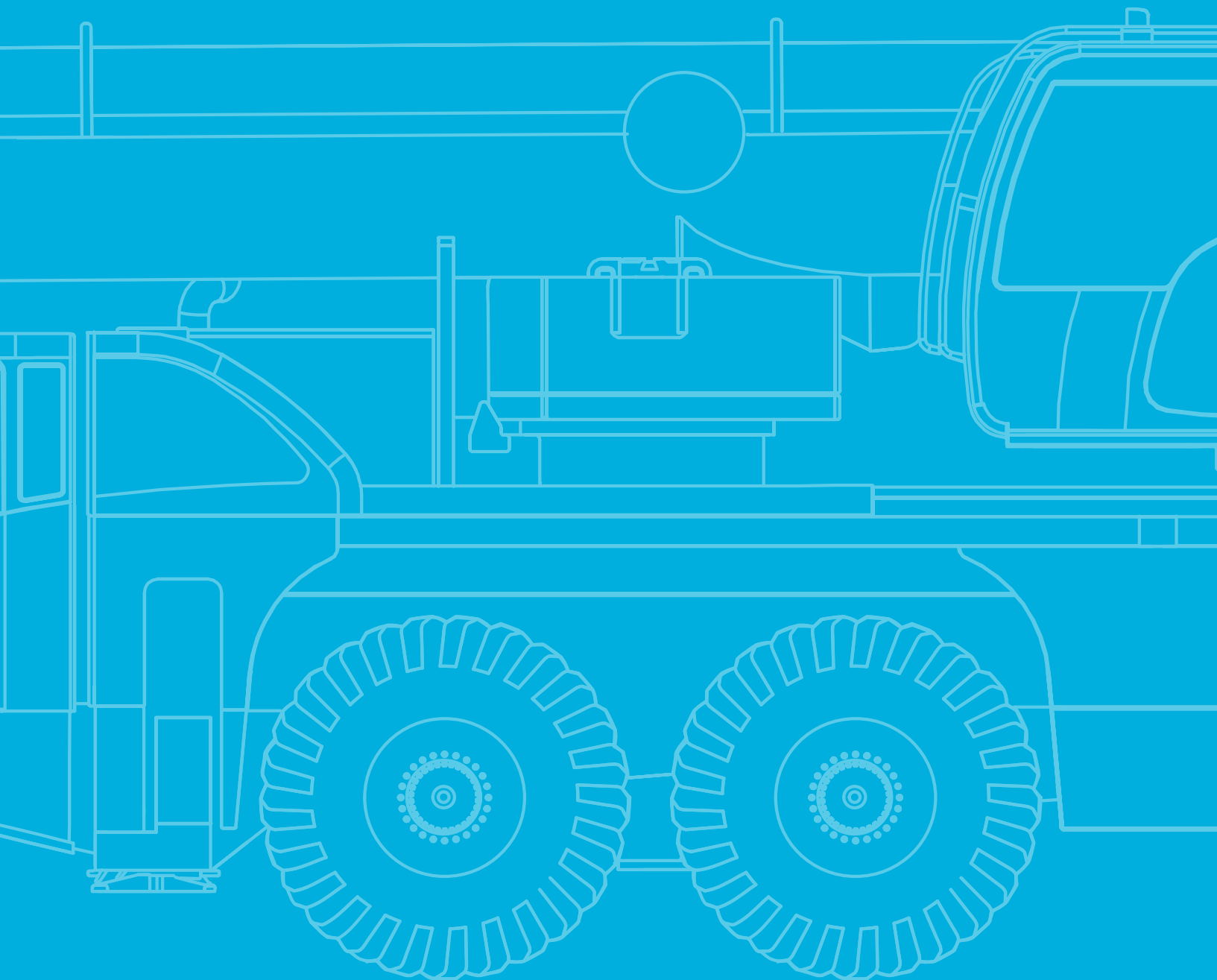

TECHNICAL DATA FOR ON-ROAD AND OFF-ROAD DRIVING



On-road and off-road driving

Axle loads											
	Total		TELMA								
< 20,000 lbs	On request!										X
< 22,050 lbs	< 88,200 lbs	8 x 6 x 8	X	385/95R25	196.9 ft	17,600 lbs	7,300 lbs	–	–	880 lbs	
< 22,050 lbs	< 88,200 lbs	8 x 4 x 8	–	445/95R25	196.9 ft	17,600 lbs	7,300 lbs	–	–	660 lbs	
< 26,500 lbs	<106,000 lbs	8 x 6 x 8	X	445/95R25	196.9 ft	44,100 lbs	20,500 lbs	52.5 ft	–	330 lbs	
< 26,500 lbs	<106,000 lbs	8 x 6 x 8	X	445/95R25	196.9 ft	110,200 lbs	20,500 lbs	21.3 ft	–	1,320 lbs	
< 26,500 lbs	<106,000 lbs	8 x 6 x 8	X	445/95R25	196.9 ft	110,200 lbs	17,600 lbs	21.3 ft	X	1,320 lbs	
< 36,400 lbs	<128,000 lbs	8 x 6 x 8	X	445/95R25	196.9 ft	110,200 lbs	39,000 lbs	21.3 ft	X	1,320 lbs	

Speeds and gradeability			
	385/95 R 25 14.00 R 25	445/95 R 25 16.00 R 25	525/80 R 25 20.50 R 25
	46 %	42 %	42 %
	> 70 %	> 60 %	> 60 %
	52.8 mph ¹⁾		

¹⁾ Depending on tire type, size and country specific legislation

Steering	
	1 Highway > 28 mph
	2 City < 28 mph
	3* Minimum turning radius < 3.1 mph
	4* Off-wall
	5* Crab steer mode
	6* All wheel steering

* must be activated

TECHNICAL DATA FOR TRANSPORT

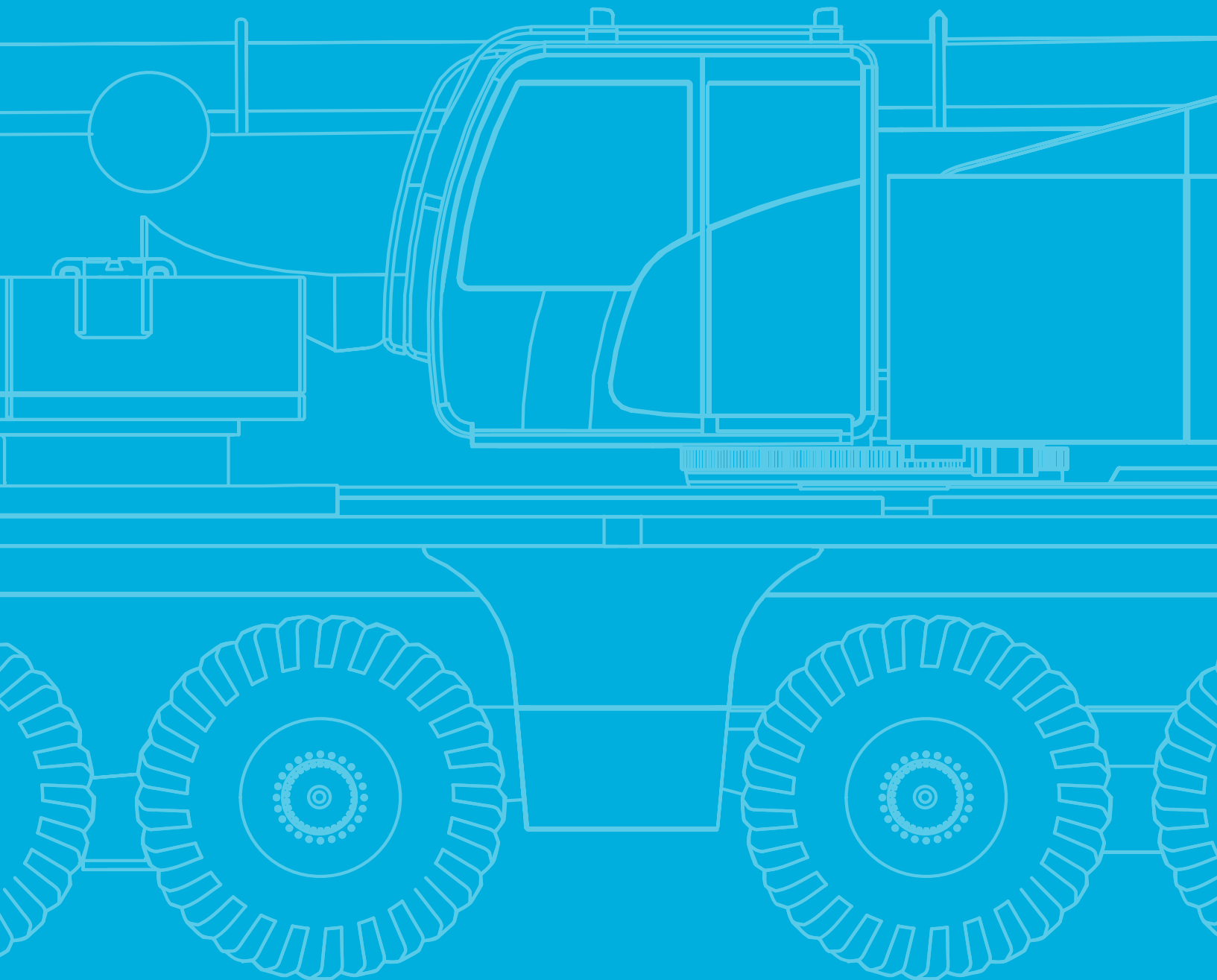

Transportation

Counterweight

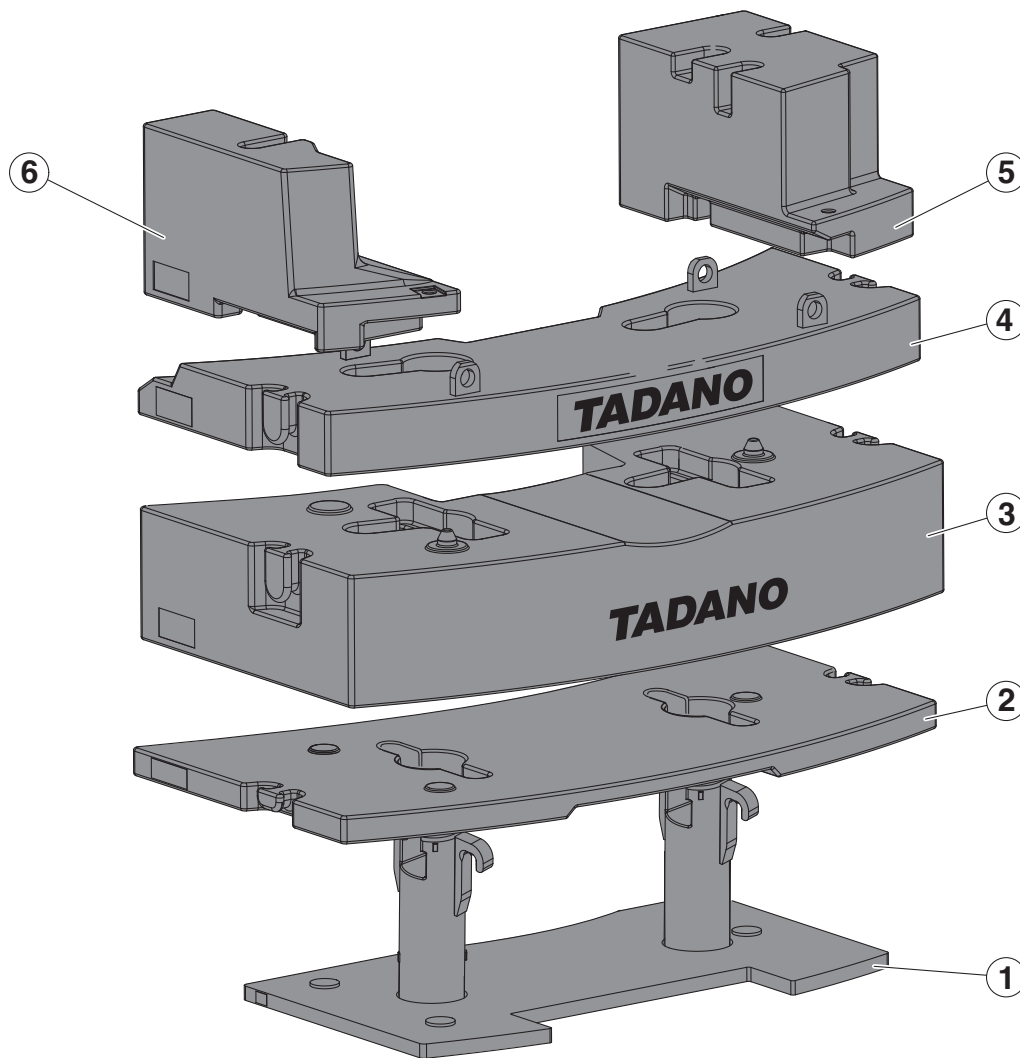

Configurations

	7,300 lbs	9,700 lbs	13,700 lbs	14,100 lbs	16,500 lbs	17,600 lbs	20,500 lbs	32,200 lbs	39,000 lbs
① 2,400 lbs		1	1		1	1	1	1	1
② 4,000 lbs			1			1	1	1	1
③ 18,500 lbs								1	1
④ 6,800 lbs				1	1	1	1		1
⑤ 4,400 lbs	1	1	1	1	1	1	1	1	1
⑥ 2,900 lbs	1	1	1	1	1		1	1	1

Transportation

Counterweight

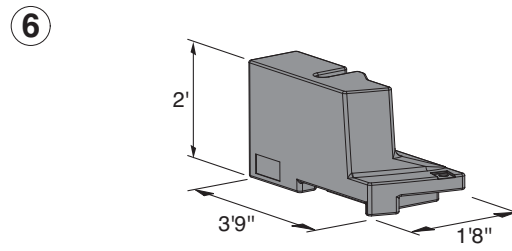
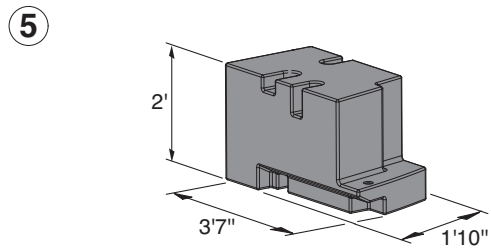
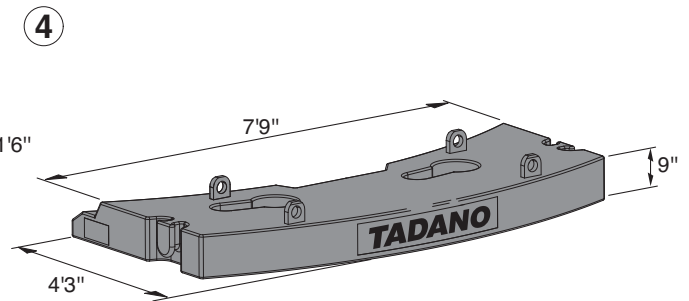
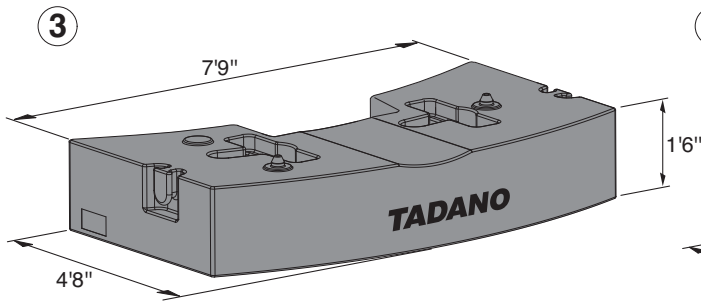
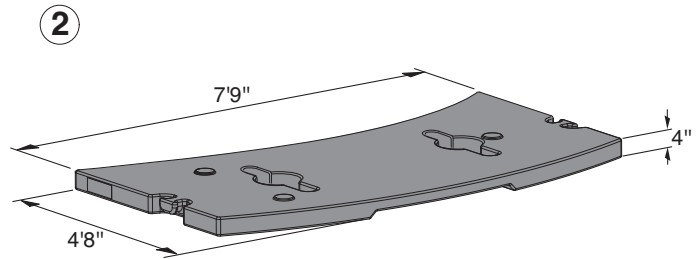
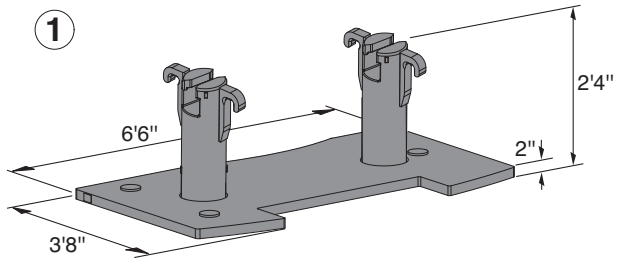

Transportation

Jib

HAV 27.9 ft / 52.5 ft

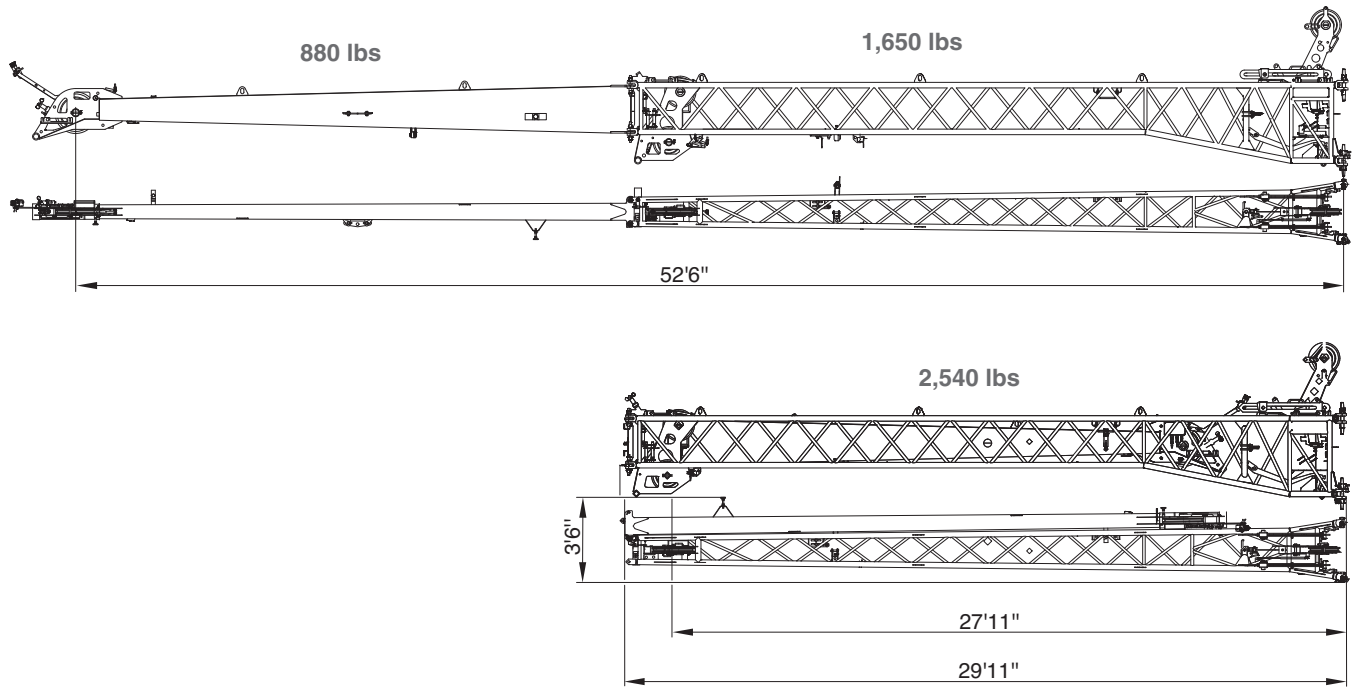

HAV 21.3 ft

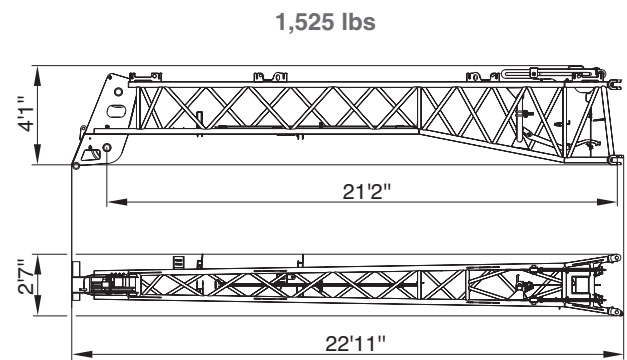

MS

450 lbs

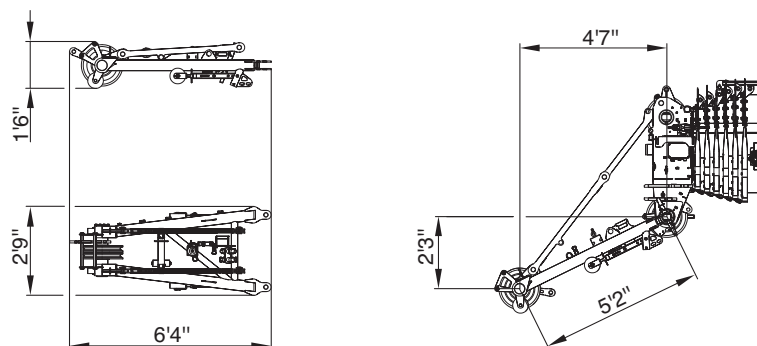

TECHNICAL DATA FOR OPERATION

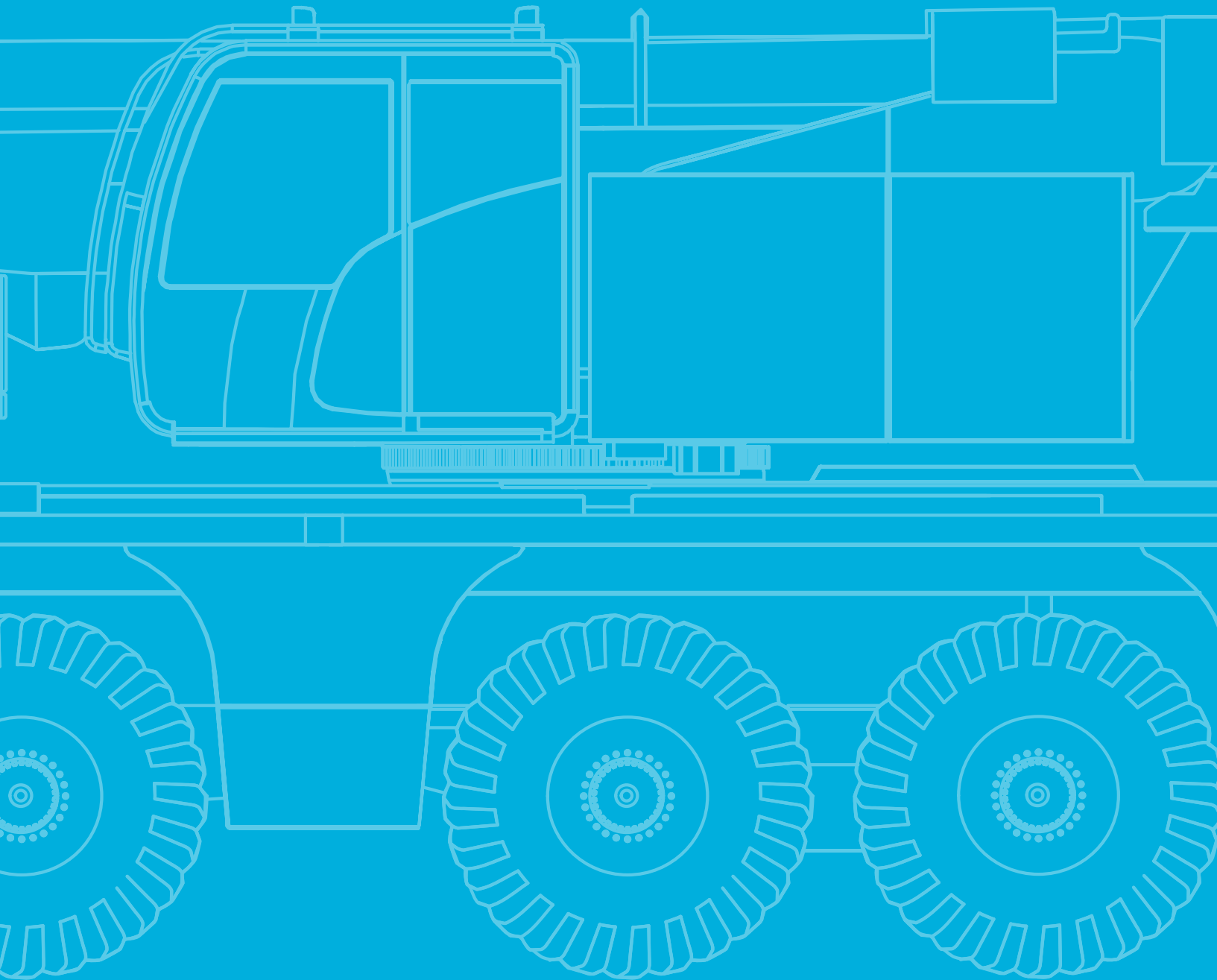

Operation

Main boom



approx. 510 s (35.8-196.9 ft)



approx. 45 s (-3° - 82°)

Slewing



1,6 min⁻¹

Hoist



393.7 ft/min

15,040 lbf

0.72"

787 ft



393.7 ft/min

15,040 lbf

0.72"

787 ft

Outrigger cylinders



86,000 lbs

110,250 lbs



28.7"

31.5"

Hook Blocks



17,600 lbs



14,900 lbs



–



1



380 lbs



3.3 ft

44,100 lbs

44,200 lbs

1

3

660 lbs

5.9 ft

110,200 lbs

87,100 lbs

3

6

1,320 lbs

5.9 ft

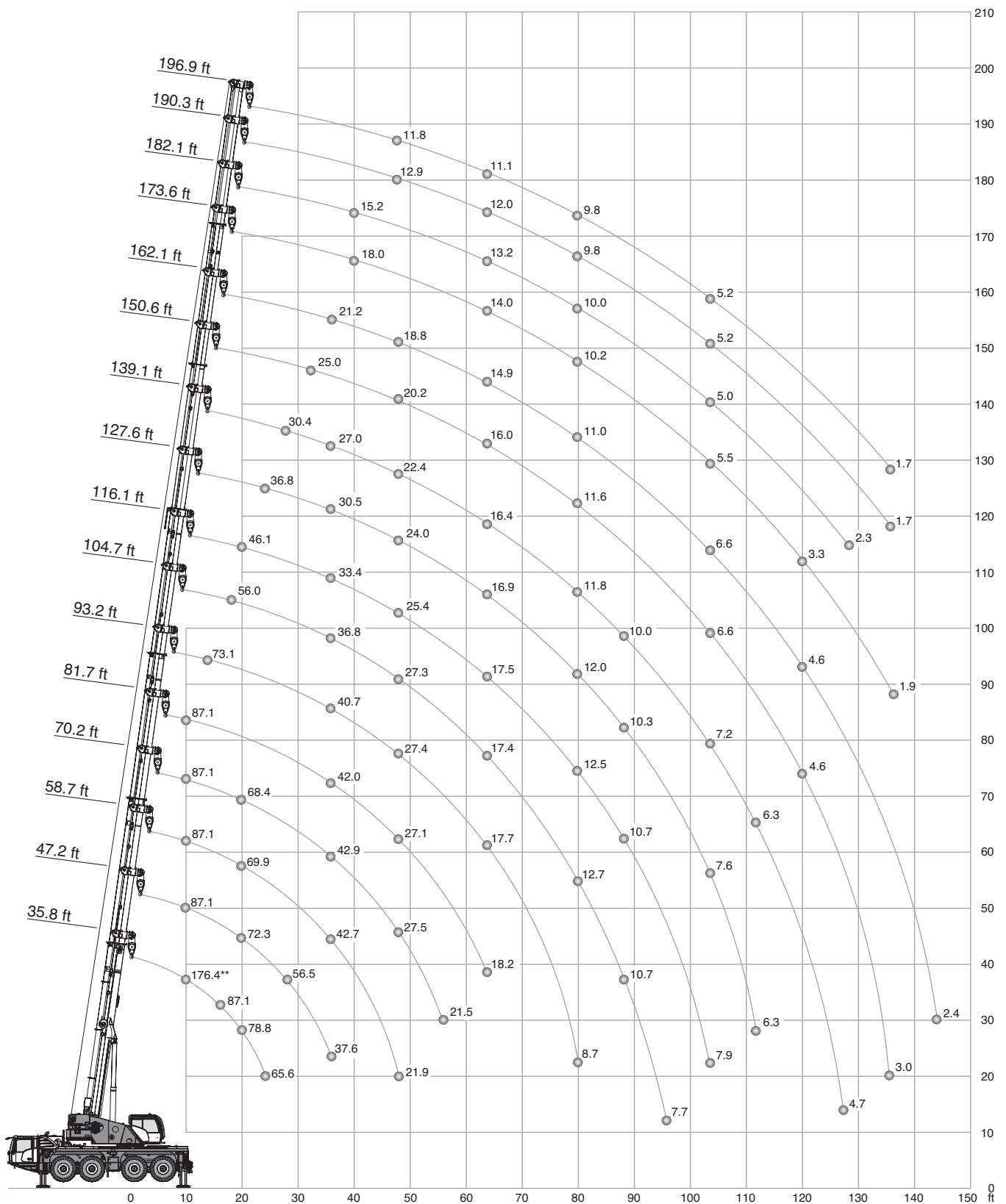

** Max. crane capacity – with additional special equipment

39,000 lbs		26.5 ft x 21.3 ft																360°		ASME B30.5	
35.8*		35.8	47.2	58.7	70.2	81.7	93.2	104.7	116.1	127.6	139.1	150.6	162.1	173.6	182.1	190.3	196.9				
ft		(ft)																ft			
10		1,000 lbs																10			
10	176.4**	-	-	-	-	-	-	-	-	-	-	-	-	-	-	-	-	-	10		
10	87.1	87.1	87.1	87.1	87.1	87.1	-	-	-	-	-	-	-	-	-	-	-	-	10		
12	87.1	87.1	87.1	87.1	87.1	86.0	-	-	-	-	-	-	-	-	-	-	-	-	12		
14	87.1	87.1	87.0	85.4	84.1	81.1	73.1	-	-	-	-	-	-	-	-	-	-	-	14		
16	87.1	85.1	83.0	80.2	78.3	76.5	72.1	-	-	-	-	-	-	-	-	-	-	-	16		
18	83.5	79.5	77.5	74.9	73.3	71.3	68.7	56.0	-	-	-	-	-	-	-	-	-	-	18		
20	78.8	73.4	72.3	69.9	68.4	66.4	64.6	53.8	46.1	-	-	-	-	-	-	-	-	-	20		
24	65.6	61.1	63.8	61.8	60.7	58.7	56.9	48.8	43.3	36.8	-	-	-	-	-	-	-	-	24		
28	-	-	56.5	55.4	54.4	52.6	50.8	44.2	39.8	35.0	30.4	-	-	-	-	-	-	-	28		
32	-	-	49.5	49.8	49.3	47.7	45.9	40.2	36.4	32.8	29.0	25.0	-	-	-	-	-	-	32		
36	-	-	37.6	42.7	42.9	42.0	40.7	36.8	33.4	30.5	27.0	24.1	21.2	-	-	-	-	-	36		
40	-	-	-	36.5	36.5	36.3	35.4	33.7	30.5	28.1	25.5	22.9	20.8	18.0	15.2	-	-	-	40		
48	-	-	-	21.9	27.5	27.1	27.4	27.3	25.4	24.0	22.4	20.2	18.8	17.4	14.7	12.9	11.8	-	48		
56	-	-	-	-	21.5	22.0	22.0	21.2	20.9	20.0	19.5	18.0	16.9	15.9	14.2	12.6	11.4	-	56		
64	-	-	-	-	-	18.2	17.7	17.4	17.5	16.9	16.4	16.0	14.9	14.0	13.2	12.0	11.1	-	64		
72	-	-	-	-	-	15.1	14.6	15.0	14.4	14.4	13.7	13.7	13.0	12.4	11.7	11.3	10.6	-	72		
80	-	-	-	-	-	-	8.7	12.7	12.5	12.0	11.8	11.6	11.0	10.2	10.0	9.8	9.8	-	80		
88	-	-	-	-	-	-	-	10.7	10.7	10.3	10.0	9.6	9.5	8.3	8.1	8.1	8.1	-	88		
96	-	-	-	-	-	-	-	7.7	9.2	8.9	8.4	8.0	8.0	6.8	6.4	6.6	6.6	-	96		
104	-	-	-	-	-	-	-	6.5	7.9	7.6	7.2	6.6	6.6	5.5	5.0	5.2	5.2	-	104		
112	-	-	-	-	-	-	-	-	-	6.3	6.3	5.5	5.5	4.3	3.9	4.1	4.1	-	112		
120	-	-	-	-	-	-	-	-	-	5.5	5.5	4.6	4.6	3.3	3.1	3.1	3.3	-	120		
128	-	-	-	-	-	-	-	-	-	-	4.7	3.7	3.7	2.5	2.3	2.4	2.5	-	128		
136	-	-	-	-	-	-	-	-	-	-	-	3.0	3.0	1.9	-	1.7	1.7	-	136		
144	-	-	-	-	-	-	-	-	-	-	-	2.2	2.4	-	-	-	-	-	144		
152	-	-	-	-	-	-	-	-	-	-	-	-	1.9	-	-	-	-	-	152		
1)	32.0	32.0	23.6	18.5	15.0	12.1	9.9	8.2	6.4	5.1	4.2	2.4	1.5	-	-	-	-	-	1)		

1) Capacities with horizontal boom

* over rear

** Max. crane capacity – with additional special equipment

Operation

HA

20,500 lbs		26.5 ft x 21.3 ft										360°		ASME B30.5					
		(ft)																	
		35.8	47.2	58.7	70.2	81.7	93.2	104.7	116.1	127.6	139.1	150.6	162.1	173.6	182.1	190.3	196.9		
ft	1,000 lbs																ft		
10	87.1	87.1	87.1	87.1	87.1	-	-	-	-	-	-	-	-	-	-	-	-	10	
12	87.1	87.1	87.1	87.1	86.0	-	-	-	-	-	-	-	-	-	-	-	-	12	
14	87.1	87.0	85.4	84.1	81.1	73.1	-	-	-	-	-	-	-	-	-	-	-	14	
16	85.1	83.0	80.2	78.3	76.5	72.1	-	-	-	-	-	-	-	-	-	-	-	16	
18	79.5	77.5	74.9	73.3	71.3	68.7	56.0	-	-	-	-	-	-	-	-	-	-	18	
20	73.4	72.3	69.9	68.4	66.4	64.5	53.8	46.1	-	-	-	-	-	-	-	-	-	20	
24	60.2	61.7	60.4	59.8	57.5	54.2	48.4	43.3	36.8	-	-	-	-	-	-	-	-	24	
28	-	47.4	49.6	49.1	47.0	44.1	41.8	38.9	35.0	30.4	-	-	-	-	-	-	-	28	
32	-	37.7	38.9	39.1	38.4	36.8	36.3	33.2	31.8	28.5	25.0	-	-	-	-	-	-	32	
36	-	26.1	32.2	32.4	32.0	32.1	31.2	29.1	27.9	26.2	23.2	21.2	-	-	-	-	-	36	
40	-	-	26.5	26.7	27.6	27.2	26.5	26.3	24.9	23.6	22.2	20.6	18.0	15.2	-	-	-	40	
48	-	-	17.2	20.7	20.5	20.2	20.7	19.9	20.0	19.4	18.5	16.8	16.0	14.3	12.9	11.8	-	48	
56	-	-	-	16.0	16.0	16.2	16.0	16.0	15.6	15.2	14.6	14.0	12.5	11.8	11.5	11.0	-	56	
64	-	-	-	-	13.1	12.9	12.9	12.7	12.3	12.3	11.6	11.1	9.6	8.9	8.7	8.7	-	64	
72	-	-	-	-	10.8	10.6	10.6	10.2	10.0	10.2	9.1	8.7	7.3	6.7	6.4	6.4	-	72	
80	-	-	-	-	-	4.2	8.8	8.3	8.1	8.1	7.0	7.0	5.5	5.1	4.9	4.9	-	80	
88	-	-	-	-	-	-	7.5	6.8	6.6	6.6	5.5	5.5	4.3	3.7	3.6	3.6	-	88	
96	-	-	-	-	-	-	6.1	5.6	5.3	5.4	4.3	4.3	3.2	2.7	2.5	2.5	-	96	
104	-	-	-	-	-	-	5.2	4.5	4.3	4.3	3.2	3.2	2.1	1.7	-	1.6	-	104	
112	-	-	-	-	-	-	-	-	3.5	3.5	2.4	2.4	-	-	-	-	-	112	
120	-	-	-	-	-	-	-	-	2.7	2.7	-	-	-	-	-	-	-	120	
128	-	-	-	-	-	-	-	-	-	2.2	-	-	-	-	-	-	-	128	
1)	32.0	23.6	18.5	13.4	10.4	7.9	6.0	4.2	2.9	2.0	-	-	-	-	-	-	-	1)	

1) Capacities with horizontal boom

Operation

HA

14,100 lbs		26.5 ft x 21.3 ft																360°		ASME B30.5	
		(ft)																			
		35.8	47.2	58.7	70.2	81.7	93.2	104.7	116.1	127.6	139.1	150.6	162.1	173.6	182.1	190.3	196.9				
ft	1,000 lbs																	ft			
10	87.1	87.1	87.1	87.1	87.1	-	-	-	-	-	-	-	-	-	-	-	-	10			
12	87.1	87.1	87.1	87.1	86.0	-	-	-	-	-	-	-	-	-	-	-	-	12			
14	87.1	87.0	85.4	84.1	81.1	73.1	-	-	-	-	-	-	-	-	-	-	-	14			
16	85.1	83.0	80.2	78.3	76.5	72.1	-	-	-	-	-	-	-	-	-	-	-	16			
18	79.5	77.5	74.9	73.3	71.3	67.3	56.0	-	-	-	-	-	-	-	-	-	-	18			
20	72.7	71.8	69.5	67.9	65.8	61.2	53.6	46.1	-	-	-	-	-	-	-	-	-	20			
24	53.6	56.6	57.4	54.8	51.5	47.8	44.7	42.2	36.5	-	-	-	-	-	-	-	-	24			
28	-	42.6	43.8	43.5	41.5	39.8	38.3	35.2	33.5	29.3	-	-	-	-	-	-	-	28			
32	-	33.0	34.3	34.5	34.3	34.1	31.8	30.8	28.9	27.3	24.0	-	-	-	-	-	-	32			
36	-	22.0	28.2	28.5	29.4	28.8	27.2	27.0	25.8	23.9	22.3	19.8	-	-	-	-	-	36			
40	-	-	23.7	24.4	24.4	23.9	24.4	23.4	22.7	21.6	20.3	18.6	17.7	15.1	-	-	-	40			
48	-	-	16.9	17.9	18.1	18.4	18.2	17.9	17.7	16.7	15.8	15.1	13.4	12.8	12.2	11.4	-	48			
56	-	-	-	13.8	14.1	14.1	14.1	13.7	13.5	13.6	12.3	11.7	10.0	9.5	9.1	9.1	-	56			
64	-	-	-	-	11.5	11.1	11.1	10.9	10.5	10.7	9.5	8.9	7.5	6.9	6.6	6.6	-	64			
72	-	-	-	-	9.3	8.9	9.1	8.6	8.2	8.4	7.3	6.9	5.3	4.9	4.7	4.7	-	72			
80	-	-	-	-	-	2.7	7.5	6.8	6.6	6.6	5.5	5.3	4.0	3.4	3.3	3.3	-	80			
88	-	-	-	-	-	-	6.0	5.5	5.1	5.3	4.3	4.0	2.7	2.3	2.1	2.1	-	88			
96	-	-	-	-	-	-	5.0	4.3	4.1	4.2	3.2	3.1	-	-	-	-	-	96			
104	-	-	-	-	-	-	4.1	3.4	3.2	3.2	2.1	2.1	-	-	-	-	-	104			
112	-	-	-	-	-	-	-	-	2.4	2.4	-	-	-	-	-	-	-	112			
1)	32.0	23.1	15.9	11.5	8.8	6.4	4.6	3.1	1.8	-	-	-	-	-	-	-	-	1)			

7,300 lbs		26.5 ft x 21.3 ft																360°		ASME B30.5	
		(ft)																			
		35.8	47.2	58.7	70.2	81.7	93.2	104.7	116.1	127.6	139.1	150.6	162.1	173.6	182.1	190.3	196.9				
ft	1,000 lbs																	ft			
10	87.1	87.1	87.1	87.1	87.1	-	-	-	-	-	-	-	-	-	-	-	-	10			
12	87.1	87.1	87.1	87.1	86.0	-	-	-	-	-	-	-	-	-	-	-	-	12			
14	87.1	87.0	85.4	84.1	81.1	73.1	-	-	-	-	-	-	-	-	-	-	-	14			
16	85.1	83.0	80.2	78.3	76.5	70.4	-	-	-	-	-	-	-	-	-	-	-	16			
18	77.6	76.0	72.4	70.5	67.3	62.1	54.0	-	-	-	-	-	-	-	-	-	-	18			
20	68.3	68.2	65.3	62.0	57.5	53.0	49.6	45.5	-	-	-	-	-	-	-	-	-	20			
24	45.6	49.4	49.7	47.4	44.4	43.0	40.3	37.4	35.0	-	-	-	-	-	-	-	-	24			
28	-	36.3	37.6	37.3	36.5	35.3	32.7	31.9	30.1	27.7	-	-	-	-	-	-	-	28			
32	-	28.1	29.2	30.0	30.4	29.1	28.4	27.3	26.1	24.5	22.9	-	-	-	-	-	-	32			
36	-	17.7	24.6	25.2	25.2	24.5	24.4	23.8	22.7	21.2	20.0	17.7	-	-	-	-	-	36			
40	-	-	20.0	20.7	21.1	21.1	21.1	20.3	19.4	18.2	17.1	16.2	14.2	13.6	-	-	-	40			
48	-	-	14.8	15.1	15.6	15.4	15.4	15.1	14.6	14.5	12.8	12.1	10.4	9.7	9.5	9.5	-	48			
56	-	-	-	11.5	12.0	11.7	11.9	11.4	11.0	11.2	9.6	9.0	7.4	6.8	6.4	6.4	-	56			
64	-	-	-	-	9.5	9.1	9.3	8.6	8.4	8.6	7.1	6.6	5.1	4.6	4.3	4.3	-	64			
72	-	-	-	-	7.5	7.1	7.3	6.7	6.4	6.7	5.3	4.9	3.3	2.9	2.7	2.7	-	72			
80	-	-	-	-	-	-	5.7	5.1	4.9	5.1	4.0	3.6	-	-	-	-	-	80			
88	-	-	-	-	-	-	4.5	4.0	3.6	3.8	2.7	2.5	-	-	-	-	-	88			
96	-	-	-	-	-	-	3.6	3.0	2.7	2.9	-	-	-	-	-	-	-	96			
104	-	-	-	-	-	-	2.7	2.3	1.9	2.1	-	-	-	-	-	-	-	104			
1)	32.0	19.4	13.2	9.5	7.1	4.9	3.5	2.0	-	-	-	-	-	-	-	-	-	1)			

1) Capacities with horizontal boom

Operation

HA

☰ 39,000 lbs		📏 26.5 ft x 14.7 ft														360°		ASME B30.5	
📏		(ft)																📏	
ft		35.8	47.2	58.7	70.2	81.7	93.2	104.7	116.1	127.6	139.1	150.6	162.1	173.6	182.1	190.3	196.9	ft	
ft		1,000 lbs																ft	
10	87.1	87.1	87.1	87.1	87.1	-	-	-	-	-	-	-	-	-	-	-	-	10	
12	87.1	87.1	87.1	87.1	86.0	-	-	-	-	-	-	-	-	-	-	-	-	12	
14	85.7	86.4	85.4	84.1	80.7	73.1	-	-	-	-	-	-	-	-	-	-	-	14	
16	79.3	80.6	80.2	78.3	74.0	68.1	-	-	-	-	-	-	-	-	-	-	-	16	
18	69.6	71.4	71.7	70.2	65.6	60.8	54.5	-	-	-	-	-	-	-	-	-	-	18	
20	59.7	62.1	64.0	61.5	57.7	53.8	50.4	45.8	-	-	-	-	-	-	-	-	-	20	
24	43.6	46.3	47.4	47.7	46.5	44.0	42.9	39.2	36.0	-	-	-	-	-	-	-	-	24	
28	-	36.0	37.1	37.2	36.9	37.7	36.1	33.8	32.0	29.3	-	-	-	-	-	-	-	28	
32	-	29.0	30.0	30.5	31.0	30.8	30.0	30.0	28.8	26.8	23.9	-	-	-	-	-	-	32	
36	-	20.6	25.4	26.3	26.3	26.0	25.9	25.7	25.3	23.9	22.4	19.9	-	-	-	-	-	36	
40	-	-	21.8	22.2	22.2	22.2	22.2	22.2	22.0	21.6	20.6	18.8	17.8	15.1	-	-	-	40	
48	-	-	16.7	16.8	17.3	17.2	17.3	16.8	16.6	16.2	15.9	15.6	13.9	13.5	12.5	11.8	-	48	
56	-	-	-	13.3	13.6	13.5	13.6	13.3	13.0	13.1	12.4	12.4	11.1	10.5	10.4	10.4	-	56	
64	-	-	-	-	11.2	10.9	11.0	10.6	10.4	10.6	9.7	9.7	8.6	8.3	8.2	8.3	-	64	
72	-	-	-	-	9.3	8.9	9.1	8.6	8.4	8.6	7.8	7.8	6.9	6.4	6.2	6.2	-	72	
80	-	-	-	-	-	4.2	7.7	7.1	6.9	7.1	6.2	6.2	5.3	4.9	4.9	4.9	-	80	
88	-	-	-	-	-	-	6.5	6.0	5.8	5.8	5.1	5.1	4.0	3.6	3.6	3.6	-	88	
96	-	-	-	-	-	-	5.4	5.1	4.7	4.9	4.1	4.1	3.0	2.7	2.5	2.5	-	96	
104	-	-	-	-	-	-	4.7	4.3	4.0	4.1	3.2	3.2	2.1	1.7	1.6	1.6	-	104	
112	-	-	-	-	-	-	-	-	3.3	3.3	2.4	2.4	-	-	-	-	-	112	
120	-	-	-	-	-	-	-	-	2.5	2.7	-	-	-	-	-	-	-	120	
128	-	-	-	-	-	-	-	-	-	2.2	-	-	-	-	-	-	-	128	
1)	32.0	21.4	15.2	11.2	8.8	6.8	5.3	4.0	2.9	2.0	-	-	-	-	-	-	-	1)	

☰ 20,500 lbs		📏 26.5 ft x 14.7 ft														360°		ASME B30.5	
📏		(ft)																📏	
ft		35.8	47.2	58.7	70.2	81.7	93.2	104.7	116.1	127.6	139.1	150.6	162.1	173.6	182.1	190.3	196.9	ft	
ft		1,000 lbs																ft	
10	87.1	87.1	87.1	87.1	86.0	-	-	-	-	-	-	-	-	-	-	-	-	10	
12	87.1	87.1	84.7	83.2	75.7	-	-	-	-	-	-	-	-	-	-	-	-	12	
14	82.0	80.1	74.5	69.6	63.8	58.3	-	-	-	-	-	-	-	-	-	-	-	14	
16	65.8	66.4	63.5	59.2	54.6	51.5	47.6	-	-	-	-	-	-	-	-	-	-	16	
18	52.9	56.1	54.9	51.7	48.0	46.4	42.7	-	-	-	-	-	-	-	-	-	-	18	
20	42.4	45.7	47.0	45.0	43.8	41.0	38.4	36.5	-	-	-	-	-	-	-	-	-	20	
24	30.5	33.2	34.4	35.6	35.1	33.4	32.2	30.8	29.1	-	-	-	-	-	-	-	-	24	
28	-	25.5	27.2	27.6	27.6	27.9	27.3	25.9	24.5	22.9	-	-	-	-	-	-	-	28	
32	-	20.3	22.0	22.3	22.7	22.6	22.6	22.1	20.9	20.0	18.2	-	-	-	-	-	-	32	
36	-	12.9	18.5	18.7	19.3	19.0	19.0	18.7	18.0	17.6	15.8	15.0	-	-	-	-	-	36	
40	-	-	15.3	15.5	16.2	16.0	16.2	15.5	15.3	15.1	13.6	13.0	11.4	10.8	-	-	-	40	
48	-	-	11.4	11.6	12.2	11.8	12.0	11.5	11.3	11.5	10.3	9.9	8.4	7.8	7.7	7.7	-	48	
56	-	-	-	8.9	9.4	9.1	9.3	8.8	8.5	8.8	7.9	7.4	6.1	5.5	5.2	5.2	-	56	
64	-	-	-	-	7.4	7.2	7.2	6.8	6.6	6.8	5.9	5.6	4.1	3.6	3.4	3.4	-	64	
72	-	-	-	-	6.0	5.5	5.8	5.3	5.1	5.3	4.4	4.0	2.7	2.0	2.0	2.0	-	72	
80	-	-	-	-	-	-	4.7	4.2	4.0	4.1	3.1	2.9	-	-	-	-	-	80	
88	-	-	-	-	-	-	3.7	3.3	3.0	3.2	2.2	-	-	-	-	-	-	88	
96	-	-	-	-	-	-	3.0	2.4	2.2	2.2	-	-	-	-	-	-	-	96	
104	-	-	-	-	-	-	2.3	1.8	-	-	-	-	-	-	-	-	-	104	
1)	23.8	14.6	10.1	7.3	5.5	4.0	2.9	1.5	-	-	-	-	-	-	-	-	-	1)	

1) Capacities with horizontal boom

Operation

HA

14,100 lbs		26.5 ft x 14.7 ft																360°		ASME B30.5	
		(ft)																			
ft		35.8	47.2	58.7	70.2	81.7	93.2	104.7	116.1	127.6	139.1	150.6	162.1	173.6	182.1	190.3	196.9	ft			
1,000 lbs																					
10	87.1	87.1	86.7	86.2	81.4	-	-	-	-	-	-	-	-	-	-	-	-	-	10		
12	85.7	83.8	79.9	73.8	66.8	-	-	-	-	-	-	-	-	-	-	-	-	-	12		
14	74.7	70.4	66.5	61.2	56.0	52.2	-	-	-	-	-	-	-	-	-	-	-	-	14		
16	57.4	59.1	55.9	51.9	49.6	45.9	42.2	-	-	-	-	-	-	-	-	-	-	-	16		
18	46.0	49.1	48.2	45.3	43.8	40.7	38.1	-	-	-	-	-	-	-	-	-	-	-	18		
20	36.6	39.8	41.1	40.7	38.4	36.9	34.9	32.6	-	-	-	-	-	-	-	-	-	-	20		
24	26.1	28.9	30.5	31.2	30.9	29.8	28.4	26.7	25.3	-	-	-	-	-	-	-	-	-	24		
28	-	22.0	23.9	24.1	24.5	24.3	23.7	22.4	21.1	20.3	-	-	-	-	-	-	-	-	28		
32	-	17.3	19.1	19.3	20.0	19.6	19.6	18.9	17.8	17.3	15.5	-	-	-	-	-	-	-	32		
36	-	10.3	15.9	16.2	16.8	16.4	16.6	16.0	15.4	14.9	13.3	12.5	-	-	-	-	-	-	36		
40	-	-	13.2	13.4	14.0	13.6	13.8	13.4	13.1	12.8	11.2	10.6	9.0	8.4	-	-	-	-	40		
48	-	-	9.7	9.7	10.3	10.0	10.3	9.7	9.4	9.7	8.4	8.0	6.3	5.8	5.5	5.3	-	-	48		
56	-	-	-	7.3	7.9	7.6	7.8	7.2	7.0	7.2	6.2	5.7	4.1	3.6	3.4	3.3	-	-	56		
64	-	-	-	-	6.1	5.8	6.1	5.6	5.3	5.4	4.3	3.9	2.5	1.9	-	-	-	-	64		
72	-	-	-	-	4.9	4.4	4.7	4.2	4.0	4.0	2.9	2.5	-	-	-	-	-	-	72		
80	-	-	-	-	-	-	3.6	3.2	2.9	3.1	-	-	-	-	-	-	-	-	80		
88	-	-	-	-	-	-	2.8	2.3	1.9	2.2	-	-	-	-	-	-	-	-	88		
96	-	-	-	-	-	-	2.0	-	-	-	-	-	-	-	-	-	-	-	96		
1)	20.3	12.1	8.6	6.0	4.4	3.1	2.0	-	-	-	-	-	-	-	-	-	-	-	1)		

7,300 lbs		26.5 ft x 14.7 ft																360°		ASME B30.5	
		(ft)																			
ft		35.8	47.2	58.7	70.2	81.7	93.2	104.7	116.1	127.6	139.1	150.6	162.1	173.6	182.1	190.3	196.9	ft			
1,000 lbs																					
10	87.1	86.3	85.8	78.7	70.1	-	-	-	-	-	-	-	-	-	-	-	-	-	10		
12	81.7	74.9	69.7	63.2	57.9	-	-	-	-	-	-	-	-	-	-	-	-	-	12		
14	63.0	61.0	56.9	52.4	49.7	45.7	-	-	-	-	-	-	-	-	-	-	-	-	14		
16	48.1	50.2	47.5	45.6	42.5	40.2	35.6	-	-	-	-	-	-	-	-	-	-	-	16		
18	38.3	41.5	40.9	39.8	37.3	35.5	33.4	-	-	-	-	-	-	-	-	-	-	-	18		
20	30.3	33.6	35.5	34.6	33.2	31.2	29.5	27.6	-	-	-	-	-	-	-	-	-	-	20		
24	21.3	24.1	26.0	26.4	26.4	25.2	24.0	22.5	21.1	-	-	-	-	-	-	-	-	-	24		
28	-	18.2	19.9	20.3	21.0	20.5	19.9	18.5	17.5	16.8	-	-	-	-	-	-	-	-	28		
32	-	14.2	15.8	16.0	16.9	16.4	16.4	15.5	14.7	14.2	12.4	-	-	-	-	-	-	-	32		
36	-	7.4	13.1	13.2	13.9	13.6	13.7	13.2	12.5	12.1	10.5	9.8	-	-	-	-	-	-	36		
40	-	-	10.7	10.8	11.4	11.2	11.4	11.0	10.5	10.2	8.8	8.2	6.4	5.7	-	-	-	-	40		
48	-	-	7.6	7.8	8.4	8.0	8.2	7.8	7.5	7.6	6.1	5.5	4.0	3.3	-	-	-	-	48		
56	-	-	-	5.7	6.2	5.9	6.1	5.6	5.3	5.6	4.0	3.5	-	-	-	-	-	-	56		
64	-	-	-	-	4.7	4.5	4.7	4.0	3.8	3.9	2.5	2.0	-	-	-	-	-	-	64		
72	-	-	-	-	3.6	3.3	3.3	2.9	2.7	2.7	-	-	-	-	-	-	-	-	72		
80	-	-	-	-	-	-	2.5	-	-	-	-	-	-	-	-	-	-	-	80		
1)	16.1	9.7	6.6	4.6	3.3	1.8	-	-	-	-	-	-	-	-	-	-	-	-	1)		

1) Capacities with horizontal boom

Operation

HA

☰ 20,500 lbs		📏 26.5 ft x 10.4 ft														360°		ASME B30.5	
📐		(ft)																📐	
ft		35.8	47.2	58.7	70.2	81.7	93.2	104.7	116.1	127.6	139.1	150.6	162.1	173.6	182.1	190.3	196.9	ft	
ft		1,000 lbs																ft	
10		83.4	77.4	71.0	64.6	60.5	-	-	-	-	-	-	-	-	-	-	-	10	
12		65.2	62.4	58.2	54.6	50.9	-	-	-	-	-	-	-	-	-	-	-	12	
14		51.0	51.8	48.9	46.9	43.7	41.4	-	-	-	-	-	-	-	-	-	-	14	
16		39.9	42.8	42.6	40.6	38.6	36.3	32.4	-	-	-	-	-	-	-	-	-	16	
18		32.9	35.9	36.7	35.9	34.3	32.4	30.6	-	-	-	-	-	-	-	-	-	18	
20		26.9	29.8	31.7	31.6	30.4	28.9	27.4	25.6	-	-	-	-	-	-	-	-	20	
24		19.7	22.1	23.9	24.1	24.6	23.6	22.5	21.1	20.0	-	-	-	-	-	-	-	24	
28		-	17.1	18.8	19.1	19.7	19.3	18.9	17.7	16.7	16.0	-	-	-	-	-	-	28	
32		-	13.6	15.2	15.4	16.1	15.6	15.7	15.0	14.2	13.7	11.9	-	-	-	-	-	32	
36		-	7.4	12.7	12.8	13.5	13.2	13.4	12.7	12.2	11.7	10.2	9.5	-	-	-	-	36	
40		-	-	10.5	10.6	11.2	11.0	11.2	10.6	10.3	9.9	8.6	8.2	6.6	6.0	-	-	40	
48		-	-	7.6	7.8	8.3	8.0	8.3	7.8	7.5	7.5	6.1	5.8	4.3	3.6	-	-	48	
56		-	-	-	5.7	6.2	6.0	6.2	5.7	5.5	5.7	4.4	3.7	2.4	-	-	-	56	
64		-	-	-	-	4.7	4.5	4.7	4.2	4.0	4.1	2.8	2.3	-	-	-	-	64	
72		-	-	-	-	3.8	3.3	3.6	3.1	2.9	2.9	1.6	-	-	-	-	-	72	
80		-	-	-	-	-	-	2.7	-	-	-	-	-	-	-	-	-	80	
1)		15.4	9.5	6.6	4.6	3.3	2.0	-	-	-	-	-	-	-	-	-	-	1)	

☰ 14,100 lbs		📏 26.5 ft x 10.4 ft														360°		ASME B30.5	
📐		(ft)																📐	
ft		35.8	47.2	58.7	70.2	81.7	93.2	104.7	116.1	127.6	139.1	150.6	162.1	173.6	182.1	190.3	196.9	ft	
ft		1,000 lbs																ft	
10		71.9	67.4	61.9	57.6	52.7	-	-	-	-	-	-	-	-	-	-	-	10	
12		56.0	54.2	51.1	48.0	44.9	-	-	-	-	-	-	-	-	-	-	-	12	
14		43.5	44.7	43.1	40.7	38.5	35.9	-	-	-	-	-	-	-	-	-	-	14	
16		33.9	36.8	36.9	35.0	33.4	31.5	27.7	-	-	-	-	-	-	-	-	-	16	
18		27.8	30.8	31.9	30.8	29.6	28.0	26.4	-	-	-	-	-	-	-	-	-	18	
20		22.6	25.4	27.4	27.0	26.3	24.8	23.5	21.9	-	-	-	-	-	-	-	-	20	
24		16.2	18.6	20.5	20.7	21.0	20.2	19.2	17.9	16.8	-	-	-	-	-	-	-	24	
28		-	14.2	16.0	16.2	16.9	16.4	15.9	14.9	13.9	13.3	-	-	-	-	-	-	28	
32		-	11.1	12.7	12.9	13.6	13.3	13.3	12.4	11.7	11.2	9.6	-	-	-	-	-	32	
36		-	5.2	10.5	10.7	11.4	11.1	11.1	10.5	10.0	9.5	8.1	7.5	-	-	-	-	36	
40		-	-	8.6	8.8	9.5	9.0	9.3	8.8	8.4	8.0	6.6	6.2	-	-	-	-	40	
48		-	-	6.1	6.3	6.8	6.5	6.7	6.3	5.9	5.7	4.4	3.9	-	-	-	-	48	
56		-	-	-	4.5	5.0	4.7	4.9	4.5	4.1	3.9	2.6	2.1	-	-	-	-	56	
64		-	-	-	-	3.7	3.4	3.6	3.1	2.7	2.6	-	-	-	-	-	-	64	
72		-	-	-	-	2.7	2.2	2.4	2.0	1.6	1.6	-	-	-	-	-	-	72	
1)		12.6	7.7	5.3	3.5	2.4	-	-	-	-	-	-	-	-	-	-	-	1)	

1) Capacities with horizontal boom

Operation

HA

7,300 lbs		26.5 ft x 10.4 ft														360°		ASME B30.5	
		(ft)																	
		35.8	47.2	58.7	70.2	81.7	93.2	104.7	116.1	127.6	139.1	150.6	162.1	173.6	182.1	190.3	196.9		
ft		1,000 lbs														ft			
10		59.7	56.6	52.8	48.7	45.0	-	-	-	-	-	-	-	-	-	-	-	10	
12		46.1	45.1	43.1	40.3	37.7	-	-	-	-	-	-	-	-	-	-	-	12	
14		35.5	37.1	36.0	34.0	32.3	30.1	-	-	-	-	-	-	-	-	-	-	14	
16		27.4	30.4	30.6	29.3	27.9	26.1	22.7	-	-	-	-	-	-	-	-	-	16	
18		22.3	25.2	26.4	25.7	24.7	23.1	21.8	-	-	-	-	-	-	-	-	-	18	
20		17.8	20.7	22.6	22.3	21.7	20.4	19.3	17.8	-	-	-	-	-	-	-	-	20	
24		12.4	15.0	16.7	17.0	17.3	16.4	15.6	14.4	13.4	-	-	-	-	-	-	-	24	
28		-	11.2	12.9	13.1	13.8	13.3	12.8	11.7	11.0	10.5	-	-	-	-	-	-	28	
32		-	8.6	10.2	10.4	11.1	10.6	10.6	9.6	9.0	8.5	7.2	-	-	-	-	-	32	
36		-	-	8.3	8.5	9.1	8.7	8.7	8.1	7.4	7.1	5.8	5.1	-	-	-	-	36	
40		-	-	6.6	6.9	7.3	7.1	7.3	6.7	6.0	5.8	4.5	3.8	-	-	-	-	40	
48		-	-	4.4	4.7	5.1	4.9	5.1	4.6	4.0	3.8	-	-	-	-	-	-	48	
56		-	-	-	3.2	3.6	3.4	3.6	2.9	2.4	2.3	-	-	-	-	-	-	56	
64		-	-	-	-	2.4	2.0	2.3	-	-	-	-	-	-	-	-	-	64	
1)		9.3	5.5	3.7	2.2	-	-	-	-	-	-	-	-	-	-	-	-	1)	

1) Capacities with horizontal boom

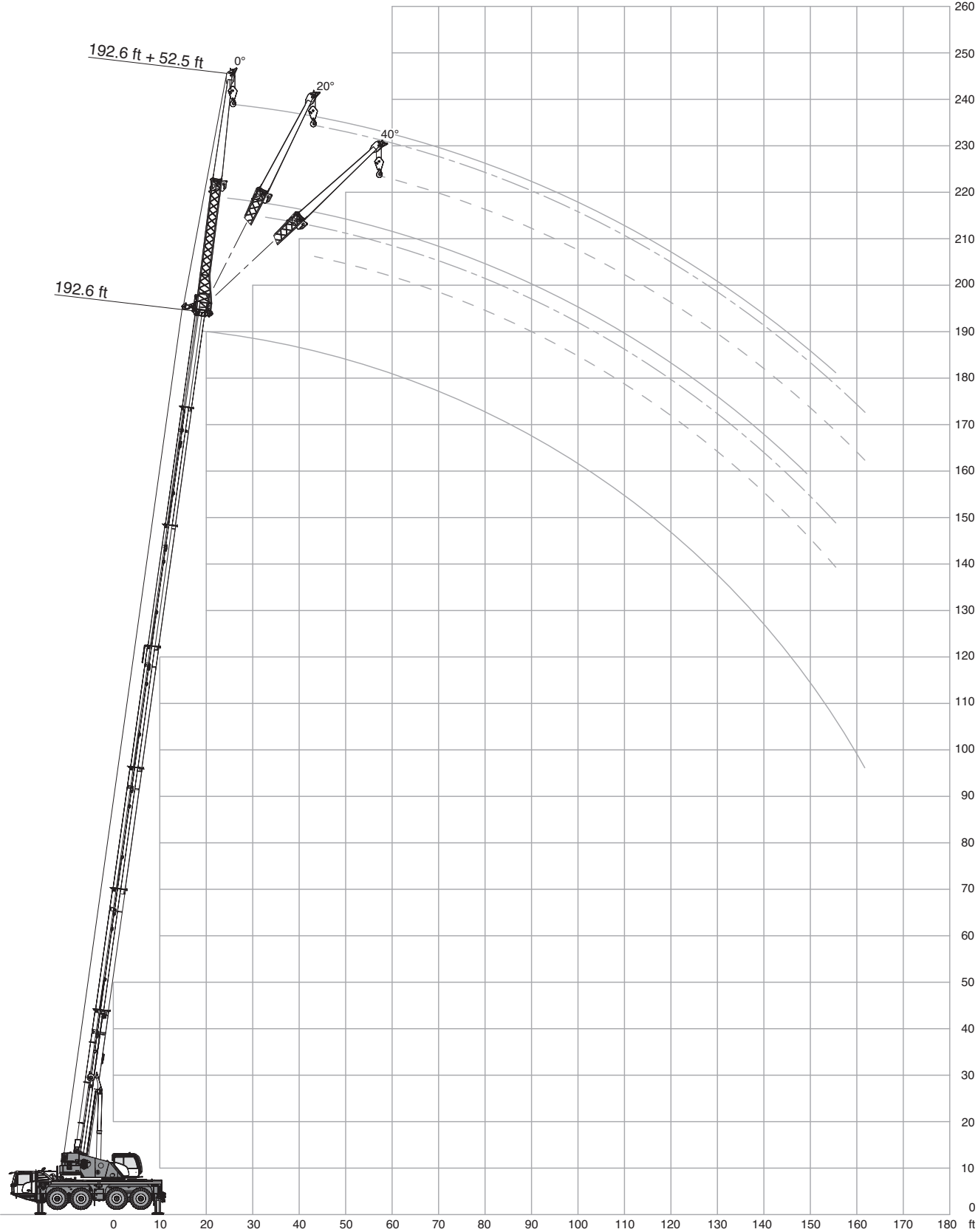

Operation

HAV

39,000 lbs		26.5 ft x 21.3 ft			27.9 ft			360°			ASME B30.5		
ft	35.8 ft			104.7 ft			173.6 ft			196.9 ft			ft
	0°	20°	40°	0°	20°	40°	0°	20°	40°	0°	20°*	40°*	
	1,000 lbs												
10	29.5	-	-	-	-	-	-	-	-	-	-	-	10
12	29.5	-	-	-	-	-	-	-	-	-	-	-	12
14	29.5	-	-	-	-	-	-	-	-	-	-	-	14
16	29.5	22.2	-	-	-	-	-	-	-	-	-	-	16
18	28.4	21.3	-	-	-	-	-	-	-	-	-	-	18
20	26.9	20.4	-	29.5	-	-	-	-	-	-	-	-	20
24	24.1	19.1	16.1	29.3	-	-	-	-	-	-	-	-	24
28	22.1	17.8	15.4	28.3	-	-	-	-	-	-	-	-	28
32	20.1	16.8	14.9	27.1	20.0	-	-	-	-	-	-	-	32
36	18.3	15.9	14.6	25.9	19.3	-	-	-	-	-	-	-	36
40	16.7	15.1	14.3	24.7	18.7	15.4	-	-	-	-	-	-	40
48	13.9	14.3	-	22.6	17.6	14.9	10.1	-	-	-	-	-	48
56	-	-	-	20.1	16.6	14.4	10.1	-	-	6.6	-	-	56
64	-	-	-	16.6	15.8	14.2	10.1	10.1	-	6.6	-	-	64
72	-	-	-	13.7	14.4	13.9	10.1	10.1	-	6.6	7.3	-	72
80	-	-	-	11.8	12.0	12.4	9.6	10.0	10.1	6.6	7.2	7.3	80
88	-	-	-	10.0	10.1	10.4	7.8	8.6	9.3	6.4	7.0	7.2	88
96	-	-	-	8.7	8.9	9.0	6.4	7.0	7.7	5.5	6.4	6.9	96
104	-	-	-	7.8	7.8	7.8	5.0	5.7	6.2	4.3	5.2	5.9	104
112	-	-	-	6.8	7.0	-	3.9	4.6	5.0	3.3	4.1	4.8	112
120	-	-	-	4.1	4.1	-	3.1	3.6	3.9	2.5	3.3	3.8	120
128	-	-	-	3.7	-	-	2.2	2.8	3.0	-	2.5	3.0	128
136	-	-	-	-	-	-	-	1.9	2.2	-	1.9	2.2	136

20,500 lbs		26.5 ft x 21.3 ft			27.9 ft			360°			ASME B30.5		
ft	35.8 ft			104.7 ft			173.6 ft			196.9 ft			ft
	0°	20°	40°	0°	20°	40°	0°	20°	40°	0°	20°*	40°*	
	1,000 lbs												
10	29.5	-	-	-	-	-	-	-	-	-	-	-	10
12	29.5	-	-	-	-	-	-	-	-	-	-	-	12
14	29.5	-	-	-	-	-	-	-	-	-	-	-	14
16	29.5	22.2	-	-	-	-	-	-	-	-	-	-	16
18	28.4	21.3	-	-	-	-	-	-	-	-	-	-	18
20	26.9	20.4	-	29.5	-	-	-	-	-	-	-	-	20
24	24.1	19.1	16.1	29.3	-	-	-	-	-	-	-	-	24
28	22.1	17.8	15.4	28.3	-	-	-	-	-	-	-	-	28
32	20.1	16.8	14.9	27.1	20.0	-	-	-	-	-	-	-	32
36	18.3	15.9	14.6	25.8	19.3	-	-	-	-	-	-	-	36
40	16.7	15.1	14.3	24.2	18.7	15.4	-	-	-	-	-	-	40
48	13.9	14.3	-	19.0	17.6	14.9	10.1	-	-	-	-	-	48
56	-	-	-	15.3	15.5	14.4	10.1	-	-	6.6	-	-	56
64	-	-	-	12.5	12.9	13.2	8.5	9.5	-	6.6	-	-	64
72	-	-	-	10.4	10.6	11.1	6.4	7.5	-	5.3	6.8	-	72
80	-	-	-	8.8	9.0	9.2	4.6	5.7	6.6	3.8	5.1	5.9	80
88	-	-	-	7.3	7.7	7.9	3.4	4.2	5.0	2.5	3.7	4.4	88
96	-	-	-	5.9	6.4	6.6	2.3	3.0	3.6	-	2.5	3.2	96
104	-	-	-	4.9	5.2	5.2	-	2.1	2.6	-	1.6	2.3	104
112	-	-	-	3.9	4.1	-	-	-	-	-	-	-	112
120	-	-	-	3.2	3.4	-	-	-	-	-	-	-	120
128	-	-	-	2.6	-	-	-	-	-	-	-	-	128

 * 192.6 ft

Operation

HAV

14,100 lbs		26.5 ft x 21.3 ft			27.9 ft			360°			ASME B30.5		
ft	35.8 ft			104.7 ft			173.6 ft			196.9 ft			ft
	0°	20°	40°	0°	20°	40°	0°	20°	40°	0°	20°*	40°*	
1,000 lbs													
10	29.5	-	-	-	-	-	-	-	-	-	-	-	10
12	29.5	-	-	-	-	-	-	-	-	-	-	-	12
14	29.5	-	-	-	-	-	-	-	-	-	-	-	14
16	29.5	22.2	-	-	-	-	-	-	-	-	-	-	16
18	28.4	21.3	-	-	-	-	-	-	-	-	-	-	18
20	26.9	20.4	-	29.5	-	-	-	-	-	-	-	-	20
24	24.1	19.1	16.1	29.3	-	-	-	-	-	-	-	-	24
28	22.1	17.8	15.4	28.3	-	-	-	-	-	-	-	-	28
32	20.1	16.8	14.9	27.1	20.0	-	-	-	-	-	-	-	32
36	18.3	15.9	14.6	24.2	19.3	-	-	-	-	-	-	-	36
40	16.7	15.1	14.3	21.9	18.7	15.4	-	-	-	-	-	-	40
48	13.9	14.3	-	17.3	17.0	14.9	10.1	-	-	-	-	-	48
56	-	-	-	13.7	14.3	14.0	9.0	-	-	6.6	-	-	56
64	-	-	-	11.3	11.5	12.0	6.4	7.8	-	5.3	-	-	64
72	-	-	-	9.1	9.5	9.9	4.5	5.6	-	3.6	4.9	-	72
80	-	-	-	7.2	7.9	8.1	3.1	4.0	4.9	-	3.5	4.4	80
88	-	-	-	5.8	6.4	6.6	-	2.7	3.5	-	2.3	2.9	88
96	-	-	-	4.7	5.2	5.4	-	-	2.3	-	-	1.9	96
104	-	-	-	3.8	4.1	4.3	-	-	-	-	-	-	104
112	-	-	-	3.0	3.3	-	-	-	-	-	-	-	112
120	-	-	-	2.3	2.5	-	-	-	-	-	-	-	120

7,300 lbs		26.5 ft x 21.3 ft			27.9 ft			360°			ASME B30.5		
ft	35.8 ft			104.7 ft			173.6 ft			196.9 ft			ft
	0°	20°	40°	0°	20°	40°	0°	20°	40°	0°	20°*	40°*	
1,000 lbs													
10	29.5	-	-	-	-	-	-	-	-	-	-	-	10
12	29.5	-	-	-	-	-	-	-	-	-	-	-	12
14	29.5	-	-	-	-	-	-	-	-	-	-	-	14
16	29.5	22.2	-	-	-	-	-	-	-	-	-	-	16
18	28.4	21.3	-	-	-	-	-	-	-	-	-	-	18
20	26.9	20.4	-	29.5	-	-	-	-	-	-	-	-	20
24	24.1	19.1	16.1	29.3	-	-	-	-	-	-	-	-	24
28	22.1	17.8	15.4	27.8	-	-	-	-	-	-	-	-	28
32	20.1	16.8	14.9	24.7	20.0	-	-	-	-	-	-	-	32
36	18.3	15.9	14.6	21.8	19.3	-	-	-	-	-	-	-	36
40	16.7	15.1	14.3	19.2	18.4	15.4	-	-	-	-	-	-	40
48	13.9	14.0	-	15.3	15.8	14.6	9.3	-	-	-	-	-	48
56	-	-	-	11.9	12.4	12.9	6.3	-	-	5.1	-	-	56
64	-	-	-	9.3	10.0	10.4	4.1	5.5	-	3.0	-	-	64
72	-	-	-	7.1	8.0	8.4	2.5	3.6	-	-	2.9	-	72
80	-	-	-	5.6	6.2	6.6	-	-	3.1	-	-	2.5	80
88	-	-	-	4.4	4.8	5.1	-	-	-	-	-	-	88
96	-	-	-	3.3	3.8	4.1	-	-	-	-	-	-	96
104	-	-	-	2.5	2.8	3.0	-	-	-	-	-	-	104
112	-	-	-	-	2.2	-	-	-	-	-	-	-	112

 * 192.6 ft

Operation

HAV

39,000 lbs		26.5 ft x 21.3 ft			52.5 ft			360°			ASME B30.5		
ft	35.8 ft			104.7 ft			173.6 ft			192.6 ft			ft
	0°	20°	40°	0°	20°	40°	0°	20°	40°	0°	20°	40°	
	1,000 lbs												
10	18.7	-	-	-	-	-	-	-	-	-	-	-	10
12	18.2	-	-	-	-	-	-	-	-	-	-	-	12
14	18.0	-	-	-	-	-	-	-	-	-	-	-	14
16	17.5	-	-	-	-	-	-	-	-	-	-	-	16
18	16.6	-	-	-	-	-	-	-	-	-	-	-	18
20	15.5	-	-	-	-	-	-	-	-	-	-	-	20
24	13.8	-	-	13.2	-	-	-	-	-	-	-	-	24
28	12.4	9.6	-	13.0	-	-	-	-	-	-	-	-	28
32	11.2	8.9	-	12.8	-	-	-	-	-	-	-	-	32
36	10.4	8.4	-	12.6	-	-	-	-	-	-	-	-	36
40	9.6	7.9	6.8	12.3	-	-	-	-	-	-	-	-	40
48	8.3	7.1	6.3	11.6	8.5	-	6.4	-	-	-	-	-	48
56	7.4	6.4	5.8	10.7	7.9	-	6.4	-	-	4.4	-	-	56
64	6.6	6.0	5.6	9.9	7.6	6.0	6.4	-	-	4.4	-	-	64
72	6.0	5.7	5.5	9.1	7.1	6.0	6.4	-	-	4.4	-	-	72
80	-	-	-	8.5	6.7	5.7	6.4	6.2	-	4.4	-	-	80
88	-	-	-	7.8	6.3	5.6	6.4	6.1	5.3	4.4	-	-	88
96	-	-	-	7.2	6.0	5.5	5.8	5.8	5.2	4.4	-	-	96
104	-	-	-	6.7	5.8	5.3	4.8	5.7	5.1	4.2	-	-	104
112	-	-	-	6.1	5.7	5.3	3.7	5.0	5.1	3.3	-	-	112
120	-	-	-	5.6	5.4	5.3	2.9	4.0	4.8	2.5	-	-	120
128	-	-	-	5.0	5.2	4.2	2.2	3.2	3.9	-	-	-	128
136	-	-	-	4.5	4.7	-	-	2.4	3.0	-	-	-	136
144	-	-	-	4.0	2.2	-	-	1.8	2.2	-	-	-	144
152	-	-	-	2.2	-	-	-	-	-	-	-	-	152

20,500 lbs		26.5 ft x 21.3 ft			52.5 ft			360°			ASME B30.5		
ft	35.8 ft			104.7 ft			173.6 ft			192.6 ft			ft
	0°	20°	40°	0°	20°	40°	0°	20°	40°	0°	20°	40°	
	1,000 lbs												
10	18.7	-	-	-	-	-	-	-	-	-	-	-	10
12	18.2	-	-	-	-	-	-	-	-	-	-	-	12
14	18.0	-	-	-	-	-	-	-	-	-	-	-	14
16	17.5	-	-	-	-	-	-	-	-	-	-	-	16
18	16.6	-	-	-	-	-	-	-	-	-	-	-	18
20	15.5	-	-	-	-	-	-	-	-	-	-	-	20
24	13.8	-	-	13.2	-	-	-	-	-	-	-	-	24
28	12.4	9.6	-	13.0	-	-	-	-	-	-	-	-	28
32	11.2	8.9	-	12.8	-	-	-	-	-	-	-	-	32
36	10.4	8.4	-	12.6	-	-	-	-	-	-	-	-	36
40	9.6	7.9	6.8	12.3	-	-	-	-	-	-	-	-	40
48	8.3	7.1	6.3	11.6	8.5	-	6.4	-	-	-	-	-	48
56	7.4	6.4	5.8	10.7	7.9	-	6.4	-	-	4.4	-	-	56
64	6.6	6.0	5.6	9.9	7.6	6.0	6.4	-	-	4.4	-	-	64
72	6.0	5.7	5.5	9.1	7.1	6.0	6.0	-	-	4.4	-	-	72
80	-	-	-	8.0	6.7	5.7	4.4	6.0	-	3.6	-	-	80
88	-	-	-	7.2	6.3	5.6	3.1	4.6	5.3	2.5	-	-	88
96	-	-	-	6.3	6.0	5.5	2.0	3.4	4.7	-	-	-	96
104	-	-	-	5.2	5.7	5.3	-	2.3	3.5	-	-	-	104
112	-	-	-	4.2	4.8	5.2	-	-	2.6	-	-	-	112
120	-	-	-	3.6	4.0	4.2	-	-	-	-	-	-	120
128	-	-	-	2.9	3.2	-	-	-	-	-	-	-	128
136	-	-	-	2.3	2.5	-	-	-	-	-	-	-	136
144	-	-	-	1.8	-	-	-	-	-	-	-	-	144

Operation

HAV

14,100 lbs		26.5 ft x 21.3 ft			52.5 ft			360°			ASME B30.5			
		35.8 ft			104.7 ft			173.6 ft			192.6 ft			
		0°	20°	40°	0°	20°	40°	0°	20°	40°	0°	20°	40°	
ft	1,000 lbs												ft	
10	18.7	-	-	-	-	-	-	-	-	-	-	-	-	10
12	18.2	-	-	-	-	-	-	-	-	-	-	-	-	12
14	18.0	-	-	-	-	-	-	-	-	-	-	-	-	14
16	17.5	-	-	-	-	-	-	-	-	-	-	-	-	16
18	16.6	-	-	-	-	-	-	-	-	-	-	-	-	18
20	15.5	-	-	-	-	-	-	-	-	-	-	-	-	20
24	13.8	-	-	-	13.2	-	-	-	-	-	-	-	-	24
28	12.4	9.6	-	-	13.0	-	-	-	-	-	-	-	-	28
32	11.2	8.9	-	-	12.8	-	-	-	-	-	-	-	-	32
36	10.4	8.4	-	-	12.6	-	-	-	-	-	-	-	-	36
40	9.6	7.9	6.8	-	12.3	-	-	-	-	-	-	-	-	40
48	8.3	7.1	6.3	-	11.6	8.5	-	6.4	-	-	-	-	-	48
56	7.4	6.4	5.8	-	10.7	7.9	-	6.4	-	-	4.4	-	-	56
64	6.6	6.0	5.6	-	9.6	7.6	6.0	5.7	-	-	4.4	-	-	64
72	6.0	5.7	5.5	-	8.6	7.1	6.0	4.0	-	-	3.3	-	-	72
80	-	-	-	-	7.7	6.6	5.7	2.7	4.4	-	-	-	-	80
88	-	-	-	-	6.2	6.2	5.6	-	3.2	4.6	-	-	-	88
96	-	-	-	-	5.0	5.7	5.4	-	2.1	3.4	-	-	-	96
104	-	-	-	-	4.1	4.8	5.1	-	-	2.3	-	-	-	104
112	-	-	-	-	3.3	3.7	4.1	-	-	-	-	-	-	112
120	-	-	-	-	2.5	3.0	3.3	-	-	-	-	-	-	120
128	-	-	-	-	2.0	2.3	-	-	-	-	-	-	-	128
136	-	-	-	-	-	1.7	-	-	-	-	-	-	-	136

7,300 lbs		26.5 ft x 21.3 ft			52.5 ft			360°			ASME B30.5			
		35.8 ft			104.7 ft			173.6 ft			192.6 ft			
		0°	20°	40°	0°	20°	40°	0°	20°	40°	0°	20°	40°	
ft	1,000 lbs												ft	
10	18.7	-	-	-	-	-	-	-	-	-	-	-	-	10
12	18.2	-	-	-	-	-	-	-	-	-	-	-	-	12
14	18.0	-	-	-	-	-	-	-	-	-	-	-	-	14
16	17.5	-	-	-	-	-	-	-	-	-	-	-	-	16
18	16.6	-	-	-	-	-	-	-	-	-	-	-	-	18
20	15.5	-	-	-	-	-	-	-	-	-	-	-	-	20
24	13.8	-	-	-	13.2	-	-	-	-	-	-	-	-	24
28	12.4	9.6	-	-	13.0	-	-	-	-	-	-	-	-	28
32	11.2	8.9	-	-	12.8	-	-	-	-	-	-	-	-	32
36	10.4	8.4	-	-	12.6	-	-	-	-	-	-	-	-	36
40	9.6	7.9	6.8	-	12.3	-	-	-	-	-	-	-	-	40
48	8.3	7.1	6.3	-	11.6	8.5	-	6.4	-	-	-	-	-	48
56	7.4	6.4	5.8	-	10.2	7.9	-	5.6	-	-	4.1	-	-	56
64	6.6	6.0	5.6	-	9.0	7.6	6.0	3.7	-	-	2.8	-	-	64
72	6.0	5.7	5.5	-	7.5	7.1	6.0	2.0	-	-	-	-	-	72
80	-	-	-	-	6.0	6.4	5.7	-	2.7	-	-	-	-	80
88	-	-	-	-	4.7	5.6	5.5	-	-	2.9	-	-	-	88
96	-	-	-	-	3.6	4.5	5.0	-	-	1.9	-	-	-	96
104	-	-	-	-	2.7	3.4	4.1	-	-	-	-	-	-	104
112	-	-	-	-	2.2	2.6	3.0	-	-	-	-	-	-	112
120	-	-	-	-	-	2.0	2.2	-	-	-	-	-	-	120

Operation

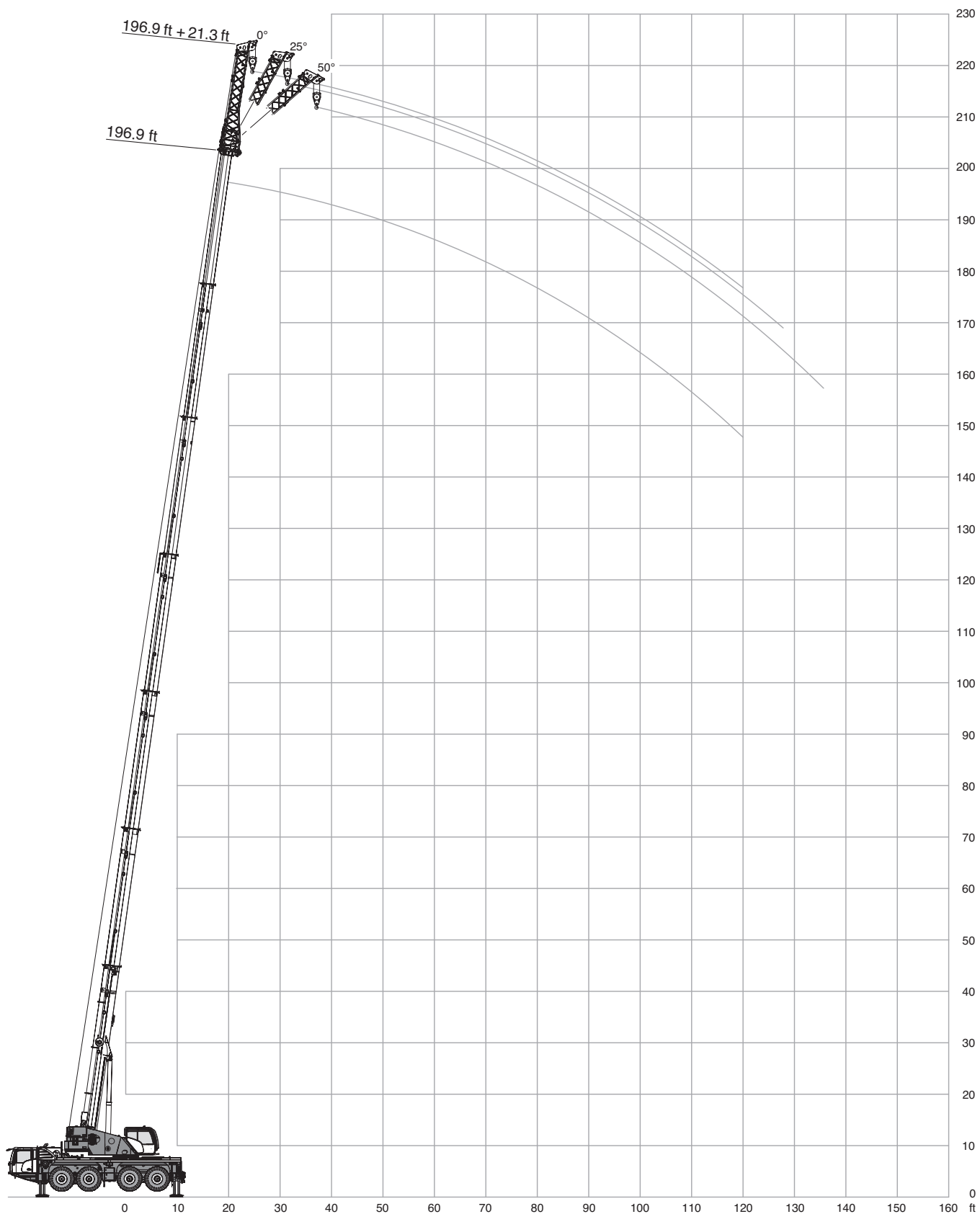

Operation

HAV

39,000 lbs		26.5 ft x 21.3 ft			21.3 ft			360°			ASME B30.5		
ft	35.8 ft			104.7 ft			173.6 ft			196.9 ft			ft
	0°	25°	50°	0°	25°	50°	0°	25°	50°	0°	25°*	50°*	
	1,000 lbs												
10	52.1	-	-	-	-	-	-	-	-	-	-	-	10
12	47.8	-	-	-	-	-	-	-	-	-	-	-	12
14	43.8	32.7	-	-	-	-	-	-	-	-	-	-	14
16	40.0	31.5	-	-	-	-	-	-	-	-	-	-	16
18	36.6	30.2	-	-	-	-	-	-	-	-	-	-	18
20	33.4	28.9	16.3	35.9	-	-	-	-	-	-	-	-	20
24	28.9	26.3	15.4	35.8	-	-	-	-	-	-	-	-	24
28	25.1	24.4	14.9	35.1	-	-	-	-	-	-	-	-	28
32	22.1	22.8	14.4	33.5	25.0	-	-	-	-	-	-	-	32
36	20.0	21.5	-	31.2	23.8	15.7	-	-	-	-	-	-	36
40	18.0	-	-	29.0	22.8	15.4	11.5	-	-	-	-	-	40
48	-	-	-	24.8	21.2	14.9	11.5	-	-	7.5	-	-	48
56	-	-	-	20.5	19.5	14.7	11.5	11.5	-	7.5	-	-	56
64	-	-	-	16.5	17.0	14.4	11.5	11.5	-	7.5	8.2	-	64
72	-	-	-	14.1	13.9	14.1	11.5	11.5	11.5	7.5	8.2	8.2	72
80	-	-	-	11.8	11.9	11.9	9.4	10.3	10.9	7.5	8.1	8.2	80
88	-	-	-	10.0	10.3	6.8	7.6	8.4	8.8	6.7	7.6	8.0	88
96	-	-	-	8.8	8.8	-	6.1	6.8	7.1	5.3	6.4	6.9	96
104	-	-	-	7.7	7.8	-	4.8	5.5	5.7	4.1	5.0	5.5	104
112	-	-	-	4.8	4.8	-	3.7	4.1	4.6	3.0	3.9	4.3	112
120	-	-	-	4.3	-	-	2.7	3.1	3.5	2.2	3.1	3.3	120
128	-	-	-	-	-	-	1.9	2.3	2.5	-	2.3	2.5	128
136	-	-	-	-	-	-	-	-	1.7	-	-	1.7	136

 * 192.6 ft

Operation

20,500 lbs		26.5 ft x 21.3 ft			21.3 ft			360°			ASME B30.5		
ft	35.8 ft			104.7 ft			173.6 ft			196.9 ft			ft
	0°	25°	50°	0°	25°	50°	0°	25°	50°	0°	25°*	50°*	
1,000 lbs													
10	52.1	-	-	-	-	-	-	-	-	-	-	-	10
12	47.8	-	-	-	-	-	-	-	-	-	-	-	12
14	43.8	32.7	-	-	-	-	-	-	-	-	-	-	14
16	40.0	31.5	-	-	-	-	-	-	-	-	-	-	16
18	36.6	30.2	-	-	-	-	-	-	-	-	-	-	18
20	33.4	28.9	16.3	35.9	-	-	-	-	-	-	-	-	20
24	28.9	26.3	15.4	35.8	-	-	-	-	-	-	-	-	24
28	25.1	24.4	14.9	35.1	-	-	-	-	-	-	-	-	28
32	22.1	22.8	14.4	32.7	25.0	-	-	-	-	-	-	-	32
36	20.0	21.5	-	28.5	23.8	15.7	-	-	-	-	-	-	36
40	18.0	-	-	24.9	22.7	15.4	11.5	-	-	-	-	-	40
48	-	-	-	19.0	19.9	14.9	11.5	-	-	7.5	-	-	48
56	-	-	-	15.1	15.7	14.4	10.6	11.3	-	7.5	-	-	56
64	-	-	-	12.4	12.8	13.1	8.4	9.6	-	7.0	8.2	-	64
72	-	-	-	10.4	10.6	11.0	6.2	7.3	8.0	5.1	6.7	7.5	72
80	-	-	-	8.6	9.0	9.2	4.4	5.5	6.1	3.5	4.9	5.7	80
88	-	-	-	7.0	7.4	6.8	3.2	4.0	4.6	2.3	3.5	4.2	88
96	-	-	-	5.7	6.1	-	2.1	2.8	3.3	-	2.3	3.0	96
104	-	-	-	4.7	5.0	-	-	1.9	2.3	-	-	1.9	104
112	-	-	-	3.9	3.9	-	-	-	-	-	-	-	112
120	-	-	-	3.2	-	-	-	-	-	-	-	-	120

14,100 lbs		26.5 ft x 21.3 ft			21.3 ft			360°			ASME B30.5		
ft	35.8 ft			104.7 ft			173.6 ft			196.9 ft			ft
	0°	25°	50°	0°	25°	50°	0°	25°	50°	0°	25°*	50°*	
1,000 lbs													
10	52.1	-	-	-	-	-	-	-	-	-	-	-	10
12	47.8	-	-	-	-	-	-	-	-	-	-	-	12
14	43.8	32.7	-	-	-	-	-	-	-	-	-	-	14
16	40.0	31.5	-	-	-	-	-	-	-	-	-	-	16
18	36.6	30.2	-	-	-	-	-	-	-	-	-	-	18
20	33.4	28.9	16.3	35.9	-	-	-	-	-	-	-	-	20
24	28.9	26.3	15.4	35.8	-	-	-	-	-	-	-	-	24
28	25.1	24.4	14.9	33.7	-	-	-	-	-	-	-	-	28
32	22.1	22.8	14.4	29.2	25.0	-	-	-	-	-	-	-	32
36	20.0	21.5	-	25.2	23.6	15.7	-	-	-	-	-	-	36
40	18.0	-	-	22.3	22.3	15.4	11.5	-	-	-	-	-	40
48	-	-	-	17.3	18.2	14.9	11.0	-	-	7.5	-	-	48
56	-	-	-	13.7	14.2	13.8	8.8	10.2	-	7.0	-	-	56
64	-	-	-	11.1	11.5	11.7	6.2	7.5	-	5.1	6.8	-	64
72	-	-	-	8.9	9.3	9.7	4.2	5.3	6.2	3.3	4.7	5.6	72
80	-	-	-	7.0	7.5	7.7	2.9	3.8	4.4	-	3.3	4.0	80
88	-	-	-	5.6	6.0	6.3	-	2.5	3.1	-	-	2.6	88
96	-	-	-	4.5	4.8	-	-	-	1.9	-	-	-	96
104	-	-	-	3.6	3.8	-	-	-	-	-	-	-	104
112	-	-	-	2.8	3.0	-	-	-	-	-	-	-	112
120	-	-	-	2.1	-	-	-	-	-	-	-	-	120

* 192.6 ft

Operation

HAV

7,300 lbs		26.5 ft x 21.3 ft			21.3 ft			360°			ASME B30.5		
ft	35.8 ft			104.7 ft			173.6 ft			196.9 ft			ft
	0°	25°	50°	0°	25°	50°	0°	25°	50°	0°	25°*	50°*	
	1,000 lbs												
10	52.1	-	-	-	-	-	-	-	-	-	-	-	10
12	47.8	-	-	-	-	-	-	-	-	-	-	-	12
14	43.8	32.7	-	-	-	-	-	-	-	-	-	-	14
16	40.0	31.5	-	-	-	-	-	-	-	-	-	-	16
18	36.6	30.2	-	-	-	-	-	-	-	-	-	-	18
20	33.4	28.9	16.3	35.9	-	-	-	-	-	-	-	-	20
24	28.9	26.3	15.4	34.7	-	-	-	-	-	-	-	-	24
28	25.1	24.4	14.9	29.9	-	-	-	-	-	-	-	-	28
32	22.1	22.8	14.4	25.6	25.0	-	-	-	-	-	-	-	32
36	20.0	21.5	-	22.1	22.3	15.7	-	-	-	-	-	-	36
40	18.0	-	-	19.4	20.3	15.4	11.3	-	-	-	-	-	40
48	-	-	-	15.4	15.8	14.5	9.1	-	-	7.0	-	-	48
56	-	-	-	11.7	12.5	12.6	6.1	7.6	-	4.9	-	-	56
64	-	-	-	9.1	9.7	10.0	3.9	5.1	-	2.8	4.4	-	64
72	-	-	-	6.9	7.5	8.0	2.2	3.3	4.2	-	2.7	3.6	72
80	-	-	-	5.3	6.0	6.2	-	-	2.7	-	-	-	80
88	-	-	-	4.1	4.6	4.8	-	-	-	-	-	-	88
96	-	-	-	3.2	3.4	-	-	-	-	-	-	-	96
104	-	-	-	2.3	2.5	-	-	-	-	-	-	-	104

 * 192.6 ft

Operation

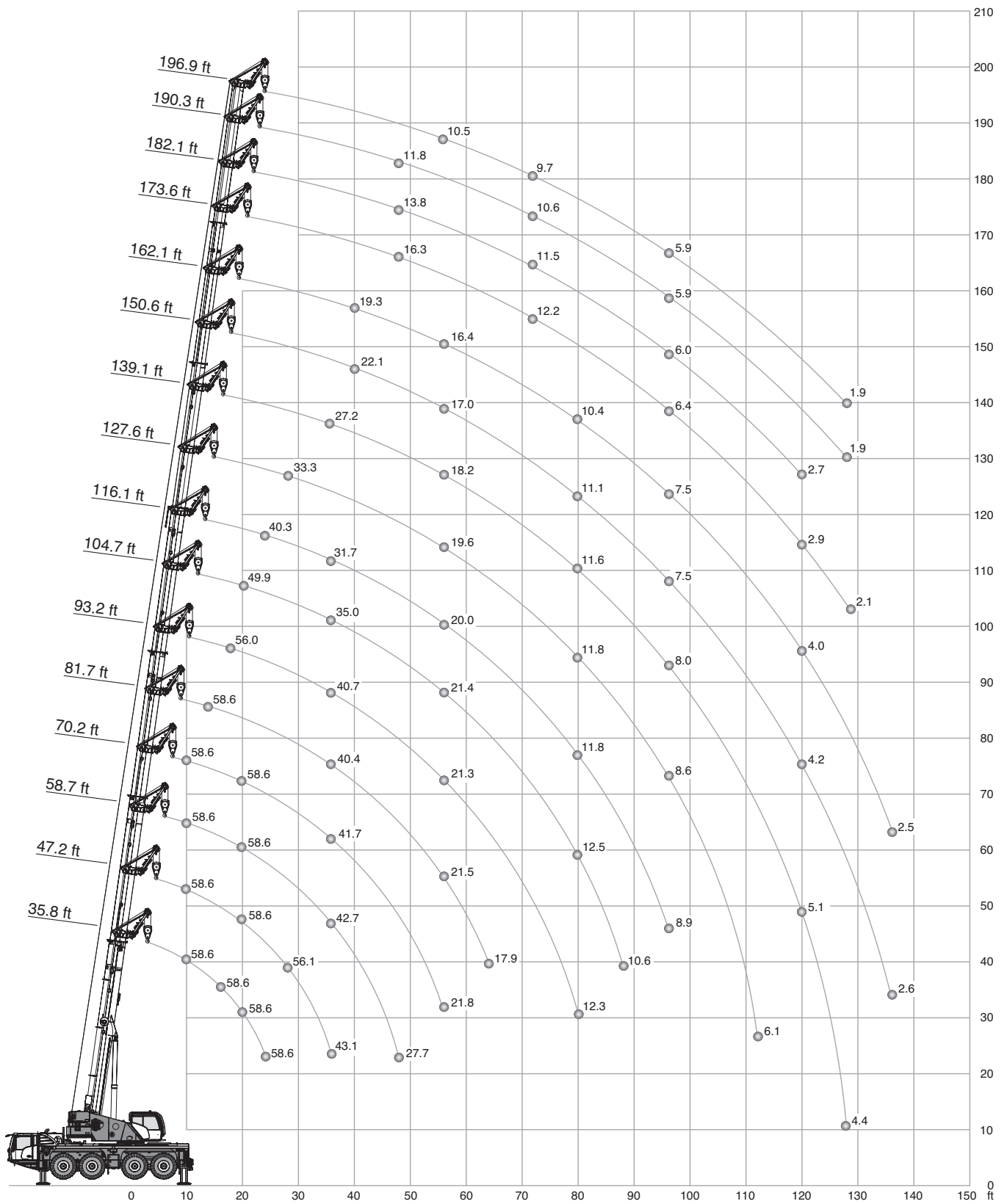

Operation

39,000 lbs		26.5 ft x 21.3 ft		5.2 ft		360°		ASME B30.5											
		(ft)																	
		35.8	47.2	58.7	70.2	81.7	93.2	104.7	116.1	127.6	139.1	150.6	162.1	173.6	182.1	190.3	196.9		
ft	1,000 lbs																ft		
10	58.6	58.6	58.6	58.6	-	-	-	-	-	-	-	-	-	-	-	-	-	10	
12	58.6	58.6	58.6	58.6	-	-	-	-	-	-	-	-	-	-	-	-	-	12	
14	58.6	58.6	58.6	58.6	58.6	-	-	-	-	-	-	-	-	-	-	-	-	14	
16	58.6	58.6	58.6	58.6	58.6	-	-	-	-	-	-	-	-	-	-	-	-	16	
18	58.6	58.6	58.6	58.6	58.6	56.0	-	-	-	-	-	-	-	-	-	-	-	18	
20	58.6	58.6	58.6	58.6	58.6	54.2	49.9	-	-	-	-	-	-	-	-	-	-	20	
24	58.6	58.6	58.1	57.5	56.8	50.8	45.8	40.3	-	-	-	-	-	-	-	-	-	24	
28	55.0	56.1	54.4	52.6	50.8	47.8	41.8	37.4	33.3	-	-	-	-	-	-	-	-	28	
32	-	50.5	49.3	47.5	45.7	44.9	38.2	34.3	30.9	27.2	-	-	-	-	-	-	-	32	
36	-	43.1	42.7	41.7	40.4	40.7	35.0	31.7	28.7	25.5	-	-	-	-	-	-	-	36	
40	-	31.9	36.0	36.3	36.7	36.0	32.0	29.2	26.8	23.8	22.1	19.3	-	-	-	-	-	40	
48	-	-	27.7	28.0	27.5	26.9	26.3	24.5	23.1	20.7	19.4	18.2	16.3	13.8	11.8	-	-	48	
56	-	-	-	21.8	21.5	21.3	21.4	20.0	19.6	18.2	17.0	16.4	15.3	13.2	11.4	10.5	-	56	
64	-	-	-	17.5	17.9	17.7	17.1	16.9	16.4	16.1	15.3	14.5	13.8	12.7	11.1	10.0	-	64	
72	-	-	-	-	15.1	14.6	14.2	14.2	13.9	13.3	13.5	12.8	12.2	11.5	10.6	9.7	-	72	
80	-	-	-	-	-	12.3	12.5	11.8	11.8	11.6	11.1	10.4	9.8	9.4	9.2	9.2	-	80	
88	-	-	-	-	-	7.0	10.6	10.3	9.9	9.7	9.2	8.9	8.0	7.6	7.4	7.4	-	88	
96	-	-	-	-	-	-	9.0	8.9	8.6	8.0	7.5	7.5	6.4	6.0	5.9	5.9	-	96	
104	-	-	-	-	-	-	6.0	7.6	7.2	6.7	6.1	6.1	5.0	4.6	4.8	4.8	-	104	
112	-	-	-	-	-	-	-	-	6.1	5.9	5.0	5.0	3.9	3.5	3.7	3.7	-	112	
120	-	-	-	-	-	-	-	-	5.1	5.1	4.2	4.0	2.9	2.7	2.7	2.7	-	120	
128	-	-	-	-	-	-	-	-	4.3	4.4	3.4	3.2	2.1	-	1.9	1.9	-	128	
136	-	-	-	-	-	-	-	-	-	2.4	2.6	2.5	-	-	-	-	-	136	
144	-	-	-	-	-	-	-	-	-	-	2.0	2.0	-	-	-	-	-	144	
1)	27.3	20.7	16.5	13.2	11.0	8.8	7.1	5.5	4.2	3.3	1.8	-	-	-	-	-	-	1)	

1) Capacities with horizontal boom

Operation

MS

☰ 20,500 lbs		🏗️ 26.5 ft x 21.3 ft		📏 5.2 ft		360°		ASME B30.5											
🔧		🔧		(ft)				🔧											
		35.8	47.2	58.7	70.2	81.7	93.2	104.7	116.1	127.6	139.1	150.6	162.1	173.6	182.1	190.3	196.9		
ft		1,000 lbs																ft	
10		58.6	58.6	58.6	58.6	-	-	-	-	-	-	-	-	-	-	-	-	-	10
12		58.6	58.6	58.6	58.6	-	-	-	-	-	-	-	-	-	-	-	-	-	12
14		58.6	58.6	58.6	58.6	58.6	-	-	-	-	-	-	-	-	-	-	-	-	14
16		58.6	58.6	58.6	58.6	58.6	-	-	-	-	-	-	-	-	-	-	-	-	16
18		58.6	58.6	58.6	58.6	58.6	56.0	-	-	-	-	-	-	-	-	-	-	-	18
20		58.6	58.6	58.6	58.6	58.6	54.2	49.9	-	-	-	-	-	-	-	-	-	-	20
24		56.8	57.4	57.5	56.6	55.4	50.4	45.8	40.3	-	-	-	-	-	-	-	-	-	24
28		47.0	48.9	49.5	47.8	45.2	44.1	40.8	37.4	33.3	-	-	-	-	-	-	-	-	28
32		-	38.2	38.7	39.2	39.1	36.6	34.6	33.0	30.6	27.2	-	-	-	-	-	-	-	32
36		-	31.4	32.8	33.1	32.8	31.1	30.1	28.5	27.3	24.6	-	-	-	-	-	-	-	36
40		-	22.1	27.2	27.2	26.9	26.7	26.7	25.1	24.0	23.2	21.0	19.1	-	-	-	-	-	40
48		-	-	20.0	20.1	20.9	20.4	19.9	20.0	19.2	18.7	18.1	16.4	15.6	13.5	11.8	-	-	48
56		-	-	-	16.1	16.1	15.9	15.9	15.7	15.4	15.0	14.2	13.4	12.0	11.3	10.7	10.2	-	56
64		-	-	-	12.7	12.9	12.9	12.9	12.5	12.3	12.0	11.2	10.7	9.1	8.5	8.3	8.3	-	64
72		-	-	-	-	10.6	10.4	10.4	10.0	9.8	9.8	8.7	8.2	6.9	6.2	6.0	6.0	-	72
80		-	-	-	-	-	8.6	8.6	8.1	7.7	7.9	6.8	6.4	5.1	4.6	4.4	4.4	-	80
88		-	-	-	-	-	2.9	7.0	6.6	6.2	6.2	5.3	5.1	3.7	3.2	2.9	3.1	-	88
96		-	-	-	-	-	-	5.8	5.3	5.0	5.0	3.9	3.9	2.5	2.1	1.9	1.9	-	96
104		-	-	-	-	-	-	4.8	4.3	3.9	3.9	3.0	2.8	-	-	-	-	-	104
112		-	-	-	-	-	-	-	-	3.0	3.0	-	-	-	-	-	-	-	112
120		-	-	-	-	-	-	-	-	2.3	2.3	-	-	-	-	-	-	-	120
1)		27.3	20.7	15.9	11.9	9.3	6.8	5.1	3.5	2.2	-	-	-	-	-	-	-	-	1)

1) Capacities with horizontal boom

Operation

14,100 lbs		26.5 ft x 21.3 ft		5.2 ft		360°		ASME B30.5											
		(ft)																	
		35.8	47.2	58.7	70.2	81.7	93.2	104.7	116.1	127.6	139.1	150.6	162.1	173.6	182.1	190.3	196.9		
ft	1,000 lbs																ft		
10	58.6	58.6	58.6	58.6	-	-	-	-	-	-	-	-	-	-	-	-	-	10	
12	58.6	58.6	58.6	58.6	-	-	-	-	-	-	-	-	-	-	-	-	-	12	
14	58.6	58.6	58.6	58.6	58.6	-	-	-	-	-	-	-	-	-	-	-	-	14	
16	58.6	58.6	58.6	58.6	58.6	-	-	-	-	-	-	-	-	-	-	-	-	16	
18	58.6	58.6	58.6	58.6	58.6	56.0	-	-	-	-	-	-	-	-	-	-	-	18	
20	58.6	58.6	58.6	58.4	58.0	54.1	49.9	-	-	-	-	-	-	-	-	-	-	20	
24	54.8	55.4	55.6	52.9	49.2	48.0	44.7	39.7	-	-	-	-	-	-	-	-	-	24	
28	41.3	43.3	43.8	42.5	41.5	38.8	36.8	34.8	31.7	-	-	-	-	-	-	-	-	28	
32	-	33.6	35.0	35.2	34.4	32.5	31.2	29.6	28.1	25.2	-	-	-	-	-	-	-	32	
36	-	28.1	29.0	29.1	28.7	27.8	27.3	25.5	24.5	23.2	-	-	-	-	-	-	-	36	
40	-	18.7	23.7	23.9	24.6	24.1	23.5	23.1	22.3	21.4	20.3	17.9	-	-	-	-	-	40	
48	-	-	17.7	18.2	18.2	17.9	17.9	17.9	17.6	16.4	15.3	14.5	12.9	12.2	11.3	-	-	48	
56	-	-	-	13.9	14.1	14.1	14.1	13.7	13.5	13.0	11.9	11.3	9.6	9.1	8.7	8.6	-	56	
64	-	-	-	10.9	11.2	11.1	11.1	10.7	10.5	10.5	9.1	8.5	7.1	6.4	6.2	6.0	-	64	
72	-	-	-	-	9.1	8.9	8.9	8.4	8.0	8.0	6.9	6.4	4.9	4.5	4.2	4.2	-	72	
80	-	-	-	-	-	7.1	7.1	6.6	6.4	6.4	5.3	4.9	3.5	2.9	2.7	2.7	-	80	
88	-	-	-	-	-	-	5.7	5.3	4.8	4.8	3.8	3.6	2.3	-	-	-	-	88	
96	-	-	-	-	-	-	4.5	4.1	3.8	3.8	2.8	2.5	-	-	-	-	-	96	
104	-	-	-	-	-	-	3.6	3.2	2.8	2.8	1.9	1.6	-	-	-	-	-	104	
112	-	-	-	-	-	-	-	-	2.0	-	-	-	-	-	-	-	-	112	
1)	27.3	19.4	13.7	10.1	7.7	5.5	4.0	2.4	-	-	-	-	-	-	-	-	-	1)	

7,300 lbs		26.5 ft x 21.3 ft		5.2 ft		360°		ASME B30.5											
		(ft)																	
		35.8	47.2	58.7	70.2	81.7	93.2	104.7	116.1	127.6	139.1	150.6	162.1	173.6	182.1	190.3	196.9		
ft	1,000 lbs																ft		
10	58.6	58.6	58.6	58.6	-	-	-	-	-	-	-	-	-	-	-	-	-	10	
12	58.6	58.6	58.6	58.6	-	-	-	-	-	-	-	-	-	-	-	-	-	12	
14	58.6	58.6	58.6	58.6	58.6	-	-	-	-	-	-	-	-	-	-	-	-	14	
16	58.6	58.6	58.6	58.6	58.6	-	-	-	-	-	-	-	-	-	-	-	-	16	
18	58.6	58.6	58.6	58.6	57.4	55.8	-	-	-	-	-	-	-	-	-	-	-	18	
20	58.1	58.2	58.0	57.6	54.9	53.0	49.4	-	-	-	-	-	-	-	-	-	-	20	
24	48.4	50.4	48.6	45.7	44.6	41.3	39.1	36.1	-	-	-	-	-	-	-	-	-	24	
28	35.0	37.1	38.1	37.9	35.8	33.9	32.5	30.5	28.1	-	-	-	-	-	-	-	-	28	
32	-	29.2	30.2	30.2	29.5	29.1	27.5	26.5	25.4	-	-	-	-	-	-	-	-	32	
36	-	23.9	24.7	24.8	25.2	24.7	23.9	22.9	22.2	20.9	-	-	-	-	-	-	-	36	
40	-	14.9	20.7	21.1	21.1	20.9	20.9	20.3	19.2	17.7	16.6	15.6	-	-	-	-	-	40	
48	-	-	15.2	15.4	15.6	15.6	15.4	15.1	14.5	14.0	12.3	11.7	10.0	9.3	9.0	-	-	48	
56	-	-	-	11.6	12.0	11.8	11.7	11.4	10.9	10.7	9.2	8.5	7.0	6.3	6.0	6.0	-	56	
64	-	-	-	8.9	9.3	9.1	9.1	8.6	8.2	8.2	6.8	6.2	4.6	4.1	3.7	3.7	-	64	
72	-	-	-	-	7.3	7.1	7.1	6.4	6.2	6.2	4.9	4.4	2.9	2.5	2.2	2.0	-	72	
80	-	-	-	-	-	5.5	5.5	4.9	4.6	4.6	3.5	2.9	-	-	-	-	-	80	
88	-	-	-	-	-	-	4.3	3.8	3.4	3.4	2.3	-	-	-	-	-	-	88	
96	-	-	-	-	-	-	3.2	2.8	2.4	2.4	-	-	-	-	-	-	-	96	
104	-	-	-	-	-	-	2.5	1.9	-	-	-	-	-	-	-	-	-	104	
1)	25.6	16.1	11.2	8.2	6.0	4.0	2.6	-	-	-	-	-	-	-	-	-	-	1)	

1) Capacities with horizontal boom

Notes to Lifting Capacity

Ratings are in compliance with ASME B30.5.
Lifting capacities do not exceed 85 % of tipping load.

Weight of hook blocks and slings is part of the load, and is to be deducted from the capacity ratings.
Consult operation manual for further details.

Note: Data published herein is intended as a guide only and shall not be construed to warrant applicability for lifting purposes.
Crane operation is subject to the computer charts and operation manual both supplied with the crane.

TECHNICAL DESCRIPTION

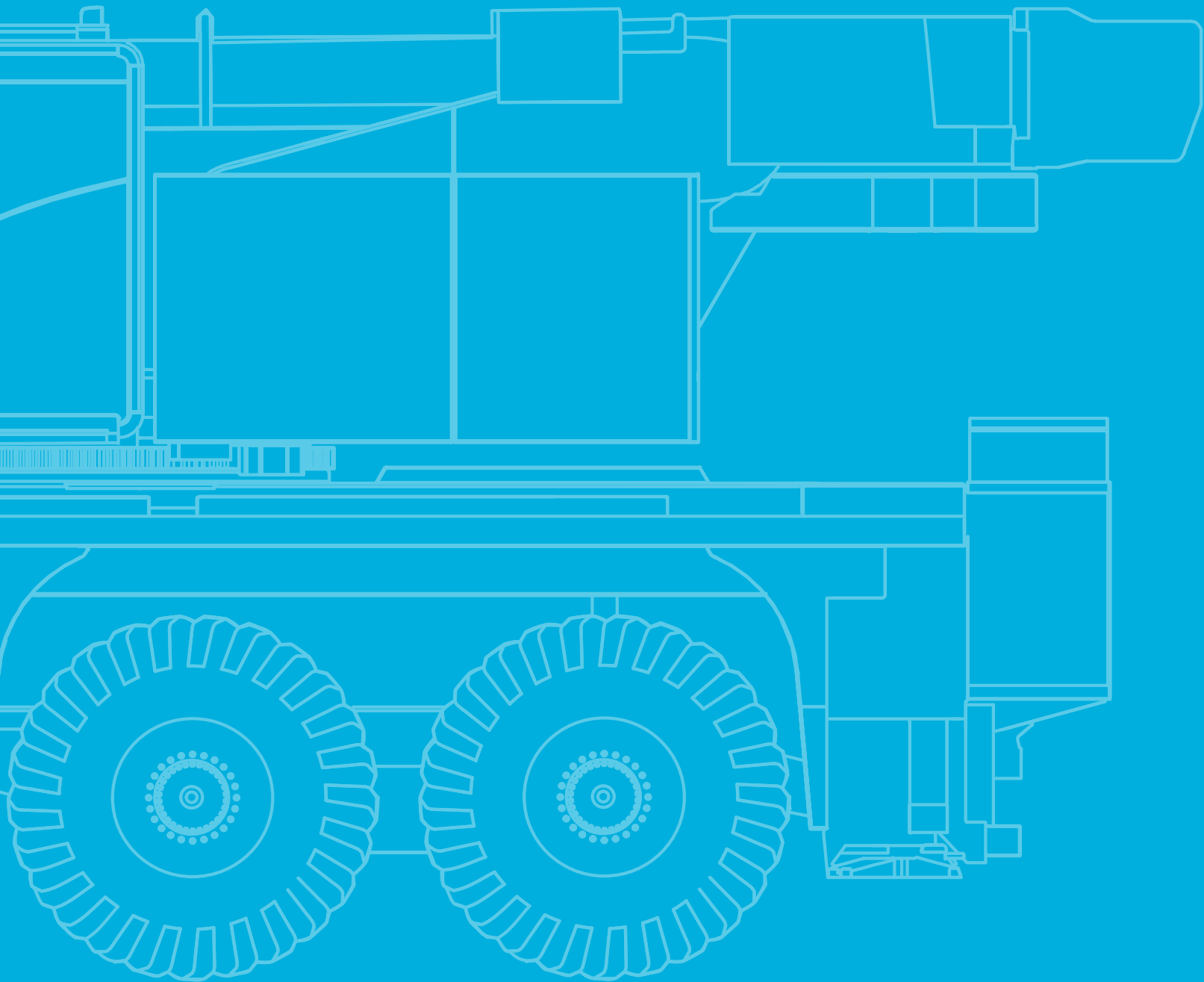

Technical Description

Basic machine

Equipment carrier

Engine 340-5	Mercedes-Benz OM471; Diesel engine; 340 kW / 1600 1/min (462 HP), torque 2300 Nm / 1300 1/min; The engine complies with EU Stage V/Tier 4F; Exhaust system complete stainless steel with SCR catalyzer.
Fuel tank	92.5 gallons Diesel (no RME / biodiesel); 11 gallons Ad-Blue tank.
Transmission G230	Mercedes-Benz G230-12; Automated gearbox with 12 forward speeds and 2 reverse; 2-stage transfer case with switchable longitudinal lock.
Axles 8 x 4 x 8	All 4 axles steered, axles 1 and 4 driven and equipped with selectable transverse lock.
Suspension	Hydropneumatic suspension with axle load compensation; Hydraulically lockable; Manual or automatic levelling alternatively.
Steering	Dual circuit hydro servocom steering with emergency steering pump; Active rear axle steering.
Brakes	Pneumatic dual circuit service brake with antilock system, acting on all wheels; Disc brakes; Additional, double-speed decompression brake; Spring-loaded parking brake.
Tires	Tires size 385/95 R25 (14.00R25); Steel rim 9,5-25/1,7"
Cab 2550	Type 8.4 ft; Adjustable driver seat, armrests and pneumatic suspension; Height and tilt-adjustable steering wheel; Auxiliary/passenger seat; Powered door windows; Tinted glass; Electrically adjustable rear-view mirrors, heated; Radio; Seat heating; Heating engine-dependent; Aircondition.
Rear view camera	Display in carrier cab; Cameras installed on rear of vehicle.
Drive lights	Including low beam, upper beam, daytime running lights, fog lights and cornering lights.
Central lubrication	Automatic central lubrication system for the lubricating points at the carrier.
Outriggers	H-4-Point design; Vertical and horizontal movement fully hydraulic; Manual or automatic levelling alternatively; 4 outrigger bases: 7.7 ft, 10.4 ft, 14.7 ft and 21.3 ft. 4 square outrigger pads A = 0.85 ft ² with transport position at vertical cylinder.
Outrigger basis monitoring	Individual monitoring of horizontal stroke; Deviation warning in crane cab.
Outrigger load indicator	The outrigger load is indicated in the operator cab and the outrigger control box.
Electronic immobiliser system	Prevents uncontrolled carrier mobilisation; Incl. 5 ignition keys.
Pneumatic tire filling plug	For self-filling of the wheels.

Equipment superstructure

Telescopic boom HA60	35.8 - 196.9 ft; Single cylinder telescoping system, automatic telescoping; Attachments for all equipment and extensions; 3 sheaves integrated in boom head for max. capacity of 87,100 lbs.
Boom luffing	1 luffing cylinder with automatic lowering brake valve.
Rotary drive	Single slewing gear unit with spring-loaded multi-disc brake.
H1	Hoist with spring-loaded multi-disc brake; Resolver (hoist rotation indicator).
Counterweight 20,500 lbs	5 pieces; Automatic rigging system.
Control system	Enabling 4 simultaneous working movements; Electric pilot controls via 2 two-axis joysticks; Different control modes selectable for hydraulic circuits.
Operator aids	IC-1, with integrated electronic load moment indicator in accordance with EN13000; Color display; Displaying of current operating conditions, load charts, fault indicator; Signal lights indicating LMI-load; Crane data logger.
IC-1 Plus incl. Flex Base	Smart crane control system for main boom operation enabling higher lifting capacities especially over outriggers. Enables safe use of the full capacity of the crane even in asymmetric outrigger configurations. Flexible and independent outrigger positioning possible. Capacity precalculation for +/- 30° slewing angle and radius area. In-cab lift simulation.
Working range limiter	Displaying and programmability of the work range limits by IC-1.
Cab 875	Type 2.87 ft; Tilt infinitely variable 16°; Sliding window rear; Fold-out front window; Extendable side pedestal, front pedestal; Handrails; Tinted safety glass; Pull-down sun visor; Radio; Seat heating; Heating engine-independent; Aircondition.
Central lubrication	Automatic central lubrication system for the lubricating points at the superstructure.

Technical Description

Additional equipment

Carrier

Engine 340-3	Mercedes-Benz OM471; Diesel engine; 340 kW / 1600 1/min (462 HP), torque 2300 Nm / 1300 1/min; The engine complies with ECE R96 (equivalent to former regulation EU Stage III A / Tier 3); Exhaust system complete stainless steel incl. spark arrester certificate.
Axles 8 x 6 x 8	All 4 axles steered, axles 1 and 4 permanently driven, axle 3 shiftable, all axles equipped with selectable transverse lock.
Wear-free auxiliary brake	Wear-free auxiliary eddy-current brake at 4th axle.
Tires	8 tires; Tire size 445/95R25 (16.00R25) or 525/80 (20.5R25).
Tadano Surround View	360° view during road travelling; Speed dependent; Indication in display of carrier cabin. Usable as assistance system when entering jobsite with indication of outrigger positions and tailswing of counterweight.

Superstructure

2. hoist (H2)	Spring-loaded multi-disc brake; Integrated resolver (hoist rotation indicator); Quick couplings; Incl. hoist monitoring.
Additional counterweight 18,500 lbs	1 piece; for total 39,000 lbs, 6 pieces.
Load supervision camera	Camera mounted on main boom head to supervise the hook block and load from above; Incl. boom head light on boom head.

Handling

Remote control	Control of superstructure movements via wireless remote control.
Moving out of crane cab	Control of carrier out of crane cab, enables machine moving when rigged, possible even under load.
E-Pack	Electro-hydraulic pump aggregate for emission free crane operation.

Extensions

HAV 21.3 ft	Lattice swing-away jib, manual offset 25°/50°; 2-sheave head; Incl. transport storage.
HAV 52.5 ft	Double folding swing-away jib, manual offset 20°/40°; 1-sheave head; Incl. transport storage; Includes HAV 29.5 ft.
MS (runner)	5.2 ft; Variable assembly jib with manual offset; 2-sheaves, for max. 58,700 lbs lifting capacity.

Hook Blocks

Vario hook block 110,200 lbs, 3-sheaves	Max. capacity 87,100 lbs; 660 lbs - 1,320 lbs; Adjustable ballast and double hook, variable usage as 1- and 3-sheaves hook block, red with white signal stripes.
Vario hook block 110,200 lbs, 3-sheaves	Max. capacity 87,100 lbs; 660 lbs - 1,320 lbs; Adjustable ballast and single hook, ariable usage as 1- and 3-sheaves hook block, red with white signal stripes.
Hook block 110,200 lbs, 3-sheaves	Max. capacity 87,100 lbs; 1,320 lbs; Double hook, red with white signal stripes.
Hook block 44,100 lbs, 1-sheave	Max. capacity 44,200 lbs; 660 lbs; Single hook, red with white signal stripes.
Hook 17,600 lbs	Max. capacity 14,900 lbs; 380 lbs; Single hook, red.

Further additional equipment on request!

Weight data may deviate from posted values based on road / travel configuration, equipment configuration, and component weight tolerances.

tac.sales@tadano.com
www.tadanoamericas.com

Tadano Europe Holdings GmbH

Dinglerstraße 24, 66482 Zweibrücken, Germany
Phone +49 6332 830

Tadano America Corporation

4242 West Greens Road, Houston, TX 77066
Phone: +1 (281) 869-00300 · Fax: +1 (281) 869-0040



Lifting your dreams

